

3116/10

Gantrail Bolted Fixing

www.gantrail.com

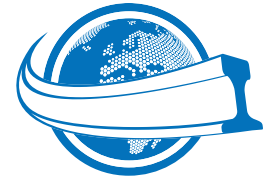

Gantrail®

A world of crane rail expertise

The GANTRAIL 3116/10 adjustable crane rail clip is designed to fix light rails in the most arduous applications. It can withstand a horizontal force from the rail of 38kN (3.9 tonnes). Its low profile allows it to be used with cranes that are fitted with guide rollers.

SPECIFICATIONS:

BOLT GRADE	8.8	10.9
MAX SIDE LOAD (kN)	38	50
BOLT TORQUE (Nm)	200	300

10mm HORIZONTAL RAIL ADJUSTMENT

DIMENSIONS (mm):

REF No.	X	Y (FULL NUT)	Y (THIN NUT)	Z	WEIGHT kg
3116/10/25	25	35	30	19	0.32
3116/10/32	32	40	35	26	0.38
3116/10/37	37	45	40	33	0.44

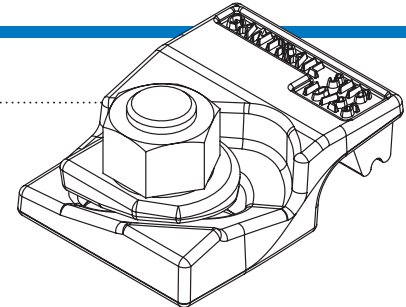

3116/10

FEATURES

- The proven design has been used successfully for many years throughout the world.
- The clip is bolted to the rail support.
- The two main parts are locked together on tightening the nut.
- The clip has a self-tightening mechanism.
- A special vulcanised rubber block applies a controlled force to the rail.

COMPONENTS

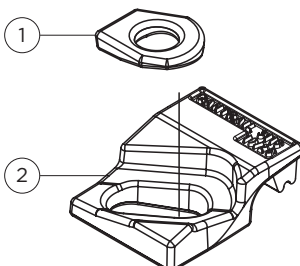

1. Special washer
2. Clip with integral rubber block

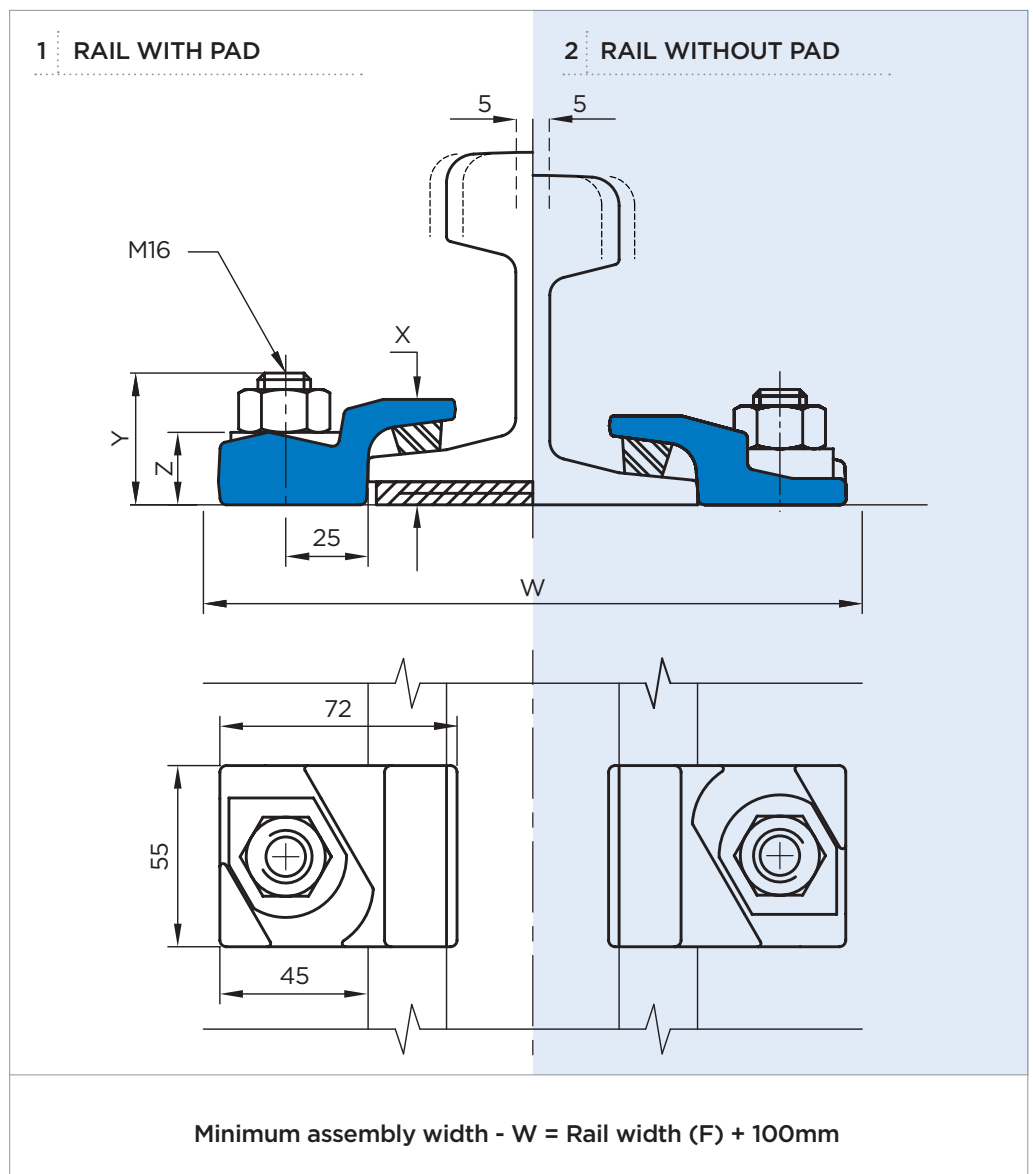

3116/10

Gantrail Bolted Fixing

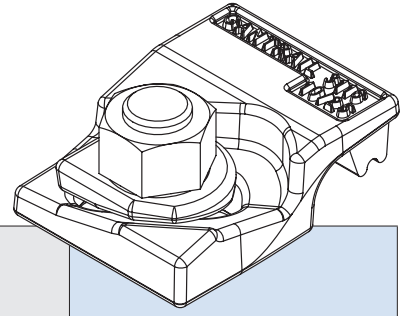

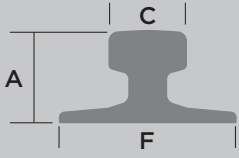
	F mm	C mm	A mm	1. CLIP REFERENCE FOR RAIL WITH PAD	2. CLIP REFERENCE FOR RAIL WITHOUT PAD
A 45	125	45	55	3116/10/32	3116/10/25
A 55	150	55	65	3116/10/32	3116/10/25
A 65	175	65	75	3116/10/32	3116/10/25
S 14	70	38	80	3116/10/32	3116/10/25
S 20	82	44	100	3116/10/32	3116/10/25
S 30	108	60	108	3116/10/32	3116/10/25
S 41	125	67	138	3116/10/32	3116/10/25
BS 50 'O'	100	52	100	3116/10/32	3116/10/25
AFNOR 26	100	50	100	3116/10/32	3116/10/25
AFNOR 30	106	56	126	3116/10/32	3116/10/25
ASCE 60	108	60	108	3116/10/32	3116/10/25
ASCE 80	127	64	127	3116/10/32	3116/10/25
ASCE 85	132	65	132	3116/10/32	3116/10/25
ISCR 22	95	50	95	3116/10/32	3116/10/25
ISCR 30	110	57	110	3116/10/32	3116/10/25
JIS 37	122	63	122	3116/10/32	3116/10/25
JIS 40	122	64	140	3116/10/32	3116/10/25
15 kg.m BHP	79	43	79	3116/10/32	3116/10/25
22 kg.m BHP	94	51	94	3116/10/32	3116/10/25
24 kg	92	51	107	3116/10/37	N/A
30 kg	107.95	60.33	107.95	3116/10/37	3116/10/37
38 kg	114	68	134	3116/10/37	3116/10/37
QU 70	120	70	120	3116/10/37	3116/10/37
QU 80	130	80	130	3116/10/37	3116/10/37
QU 100	150	100	150	3116/10/37	3116/10/37

This clip can be used for a wider selection of rails than illustrated.

Please contact GANTRAIL for the full range of possible rails. All rails can be fastened with bolted or welded base clips. GANTRAIL may change or improve their products and also alter specifications without notice.

INSTALLATION INSTRUCTIONS:

The hexagon headed fixing bolt can be inserted from above or below the supporting structure - see adjacent configurations.

If it is desired to fix the clip with a welded stud, this may be possible. Please consult GANTRAIL for guidance.

TIGHTENING TORQUE
Grade 8.8 bolt 200Nm
Grade 10.9 bolt 300Nm

Please contact GANTRAIL, for full installation instructions.

BOLT CONFIGURATIONS

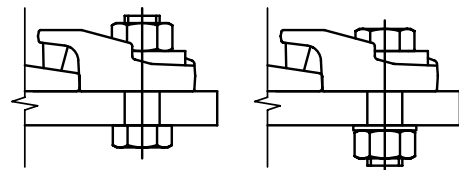

POSITIONING OF SPECIAL WASHER

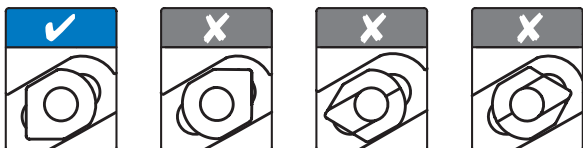

Gantry Railing Ltd
Unit 11A
Barnett Way
Barnwood
Gloucester GL4 3QA
United Kingdom

Tel: +44 (0) 1452 300688
E-mail: info@gantrail.com

