

3124/15

Gantrail Bolted Fixing

www.gantrail.com



Gantrail[®]

A world of crane rail expertise

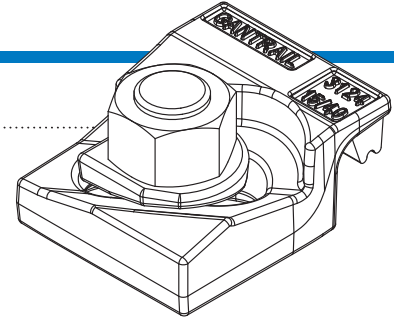

3124/15

The **GANTRAIL 3124/15** adjustable crane rail clip is designed to fix the largest rails in the most arduous applications. It can withstand a horizontal force from the rail of 125kN (12.7 tonnes). Its low profile allows it to be used with cranes that are fitted with guide rollers.

SPECIFICATIONS:

BOLT GRADE	8.8	10.9
MAX SIDE LOAD (kN)	125	140
BOLT TORQUE (Nm)	600	750

15mm HORIZONTAL RAIL ADJUSTMENT

DIMENSIONS (mm):

REF No.	X	Y (FULL NUT)	Y (THIN NUT)	Z	WEIGHT kg
3124/15/40	40	55	45	30	0.73
3124/15/53	53	55	45	30	0.82

FEATURES

- The proven design has been used successfully for many years throughout the world.
- The clip is bolted to the rail support.
- The two main parts are locked together on tightening the nut.
- A special vulcanised rubber block applies a controlled force to the rail.

COMPONENTS

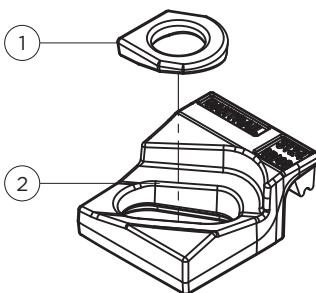

1. Special washer
2. Clip with integral rubber block

1 RAIL WITH PAD

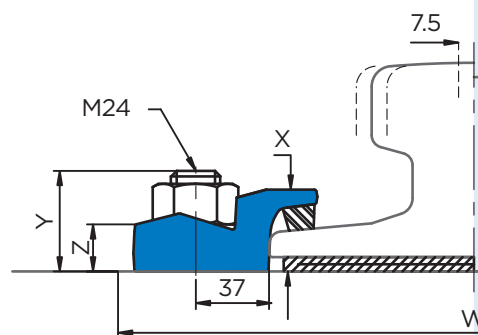

2 RAIL WITHOUT PAD

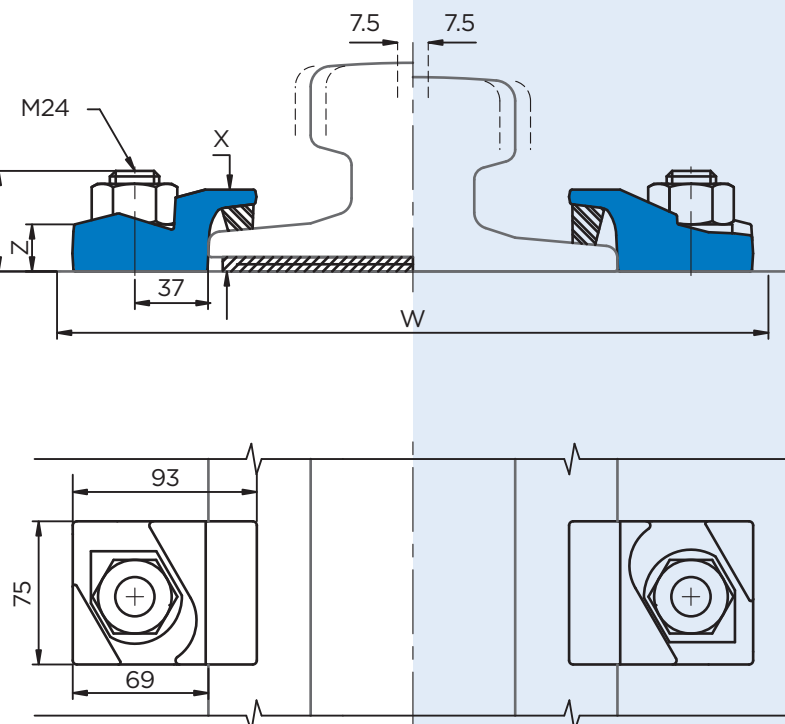

Minimum assembly width - $W = \text{Rail width (F)} + 150\text{mm}$

3124/15

Gantrail Bolted Fixing

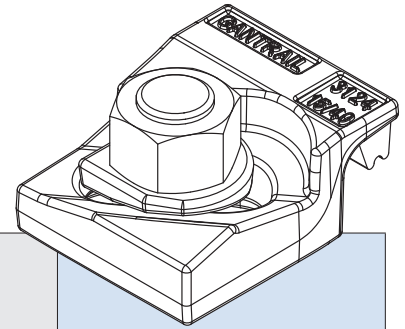

	F mm	C mm	A mm	1. CLIP REFERENCE FOR RAIL WITH PAD	2. CLIP REFERENCE FOR RAIL WITHOUT PAD
A 100	200	100	95	3124/15/40	3124/15/40
A 120	220	120	105	3124/15/40	3124/15/40
A 150	220	150	150	3124/15/40	3124/15/40
S 54	125	67	154	3124/15/40	3124/15/40
MRS 67 (135 CR)	132	79	146	3124/15/40	3124/15/40
MRS 86	165	102	102	3124/15/40	3124/15/40
MRS 87 A (PRI85R)	152	102	152	3124/15/40	3124/15/40
MRS 87 B (175 CR)	152	102	152	3124/15/40	3124/15/40
MRS 125	180	120	180	3124/15/53	3124/15/40
GCR 108	263	61 + 61	100	3124/15/40	-
GCR 183	280	75	120	3124/15/40	3124/15/40
ISCR 100	150	102	150	3124/15/40	3124/15/40
ISCR 120	170	120	170	3124/15/40	3124/15/40
QU 100	150	100	150	3124/15/40	3124/15/40
QU 120	170	120	170	3124/15/40	3124/15/40
JIS 50	127	63	145	3124/15/40	3124/15/40
JIS 60	145	64	174	3124/15/40	3124/15/40
CR 73	140	100	135	3124/15/40	3124/15/40
UIC 54 E	125	66	161	3124/15/40	3124/15/40

This clip can be used for a wider selection of rails than illustrated.

Please contact GANTRAIL for the full range of possible rails. All rails can be fastened with bolted or welded base clips. GANTRAIL may change or improve their products and also alter specifications without notice.

INSTALLATION INSTRUCTIONS:

The hexagon headed fixing bolt can be inserted from above or below the supporting structure – see adjacent configurations.

If it is desired to fix the clip with a welded stud, this may be possible. Please consult GANTRAIL for guidance.

TIGHTENING TORQUE
Grade 8.8 bolt 600Nm
Grade 10.9 bolt 750Nm

Please contact GANTRAIL, for full installation instructions.

BOLT CONFIGURATIONS

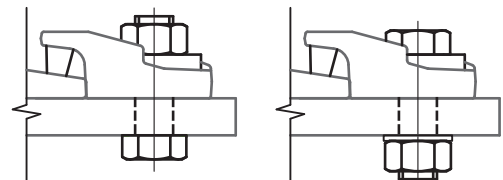

POSITIONING OF SPECIAL WASHER

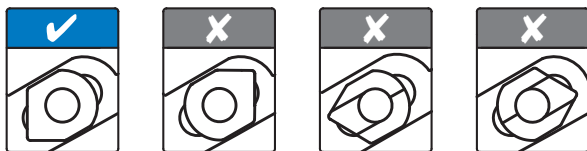

A world of crane rail expertise.

www.gantrail.com



Gantry Railing Ltd
Unit 11A
Barnett Way
Barnwood
Gloucester GL4 3QA
United Kingdom

Tel: +44 (0) 1452 300688
E-mail: info@gantrail.com



3124/15/DO/01/25