

3226/15

Gantrail Bolted Fixing

www.gantrail.com



Gantrail[®]

A world of crane rail expertise

The **GANTRAIL 3226/15** adjustable crane rail clip is designed to fix the largest of rails in the most arduous applications. It can withstand a horizontal force from the rail of 250kN (25.5 tonnes). Its low profile allows it to be used with cranes that are fitted with guide rollers.

SPECIFICATIONS:

MAX SIDE LOAD
using Grade 8.8 bolt 250kN
15mm HORIZONTAL RAIL ADJUSTMENT

DIMENSIONS (mm):

REF No.	X	Y (FULL NUT)	Y (THIN NUT)	Z	WEIGHT kg
3226/15/40	40	55	45	30	1.50

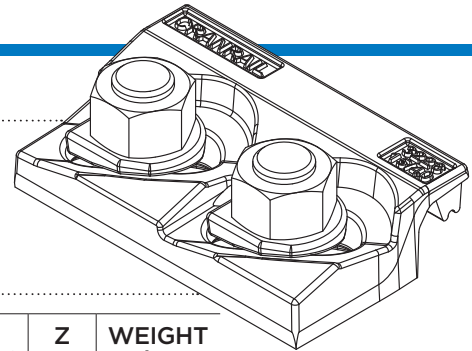

3226/15

FEATURES

- The proven design has been used successfully for many years throughout the world.
- The clip is bolted to the rail support.
- The two main parts are locked together on tightening the nut.
- A special vulcanised rubber block applies a controlled force to the rail.

COMPONENTS

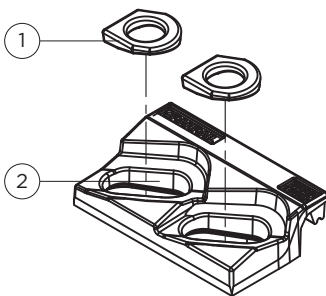

1. Special washer
2. Clip with integral rubber block

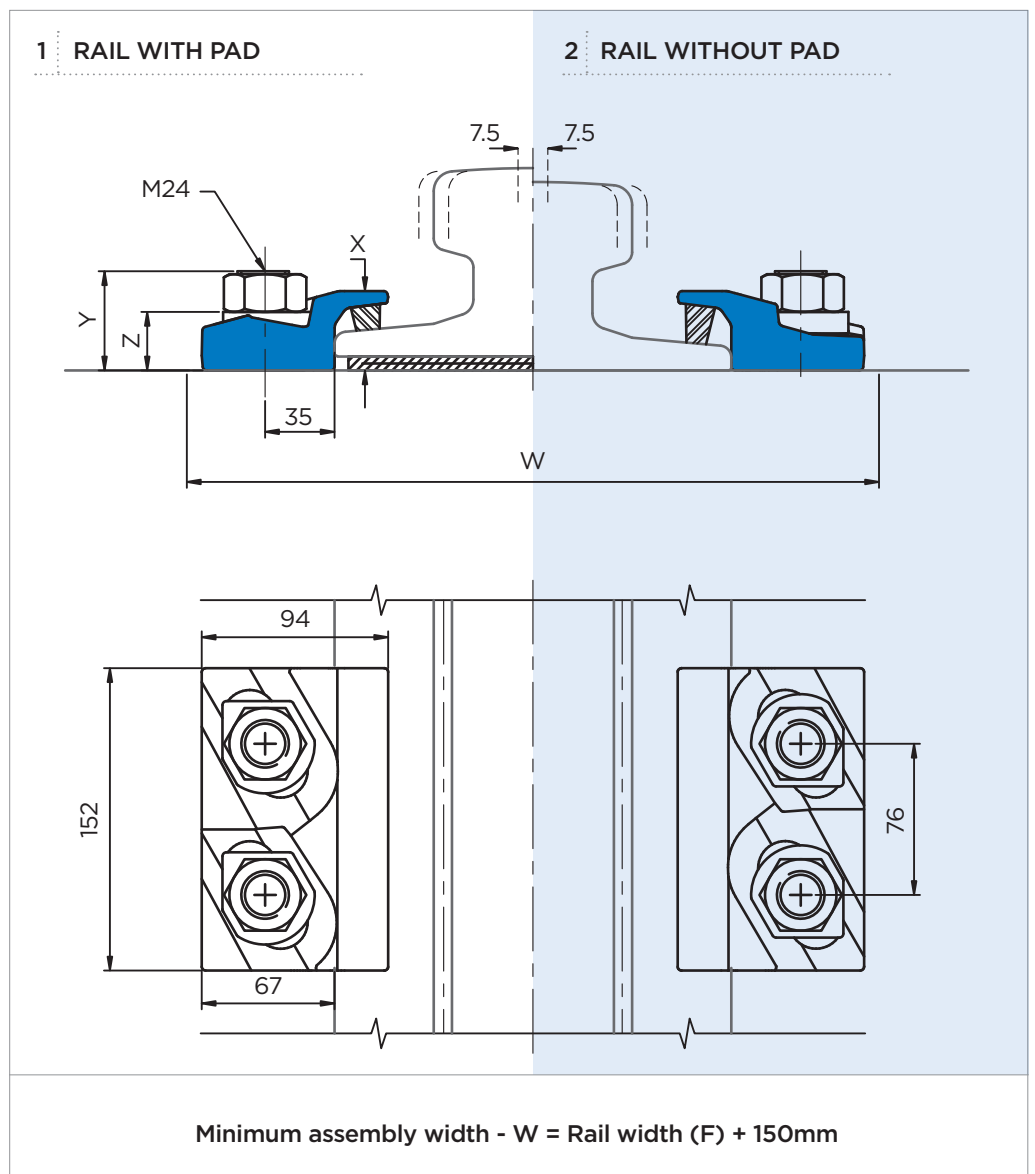

3226/15

Gantrail Bolted Fixing

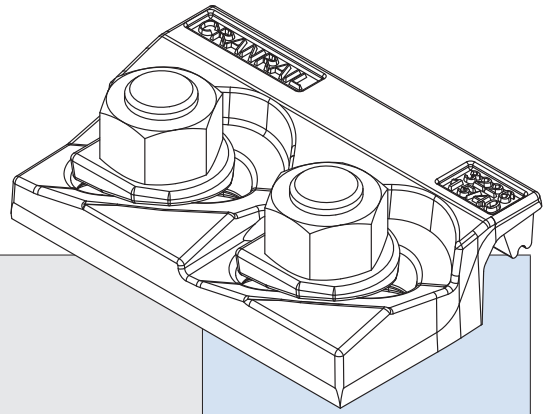

	F mm	C mm	A mm	1. CLIP REFERENCE FOR RAIL WITH PAD	2. CLIP REFERENCE FOR RAIL WITHOUT PAD
A 120	220	120	105	3226/15/40	3226/15/40
A 150	220	150	150	3226/15/40	3226/15/40
MRS 86	165	102	102	3226/15/40	3226/15/40
MRS 87 A (PRI85R)	152	102	152	3226/15/40	3226/15/40
MRS 87 B (175 CR)	152	102	152	3226/15/40	3226/15/40
GCR 183	280	75	120	3226/15/40	3226/15/40
ISCR 100	150	102	150	3226/15/40	3226/15/40
ISCR 120	170	120	170	3226/15/40	3226/15/40
QU 100	150	100	150	3226/15/40	3226/15/40
QU 120	170	120	170	3226/15/40	3226/15/40
JIS 50	127	63	145	3226/15/40	3226/15/40
CR 73	140	100	135	3226/15/40	3226/15/40
86 kg AS	165	102	102	3226/15/40	3226/15/40

This clip can be used for a wider selection of rails than illustrated.

Please contact GANTRAIL for the full range of possible rails. All rails can be fastened with bolted or welded base clips. GANTRAIL may change or improve their products and also alter specifications without notice.

INSTALLATION INSTRUCTIONS:

The hexagon headed fixing bolt can be inserted from above or below the supporting structure – see adjacent configurations.

If it is desired to fix the clip with a welded stud, this may be possible. Please consult GANTRAIL for guidance.

TIGHTENING TORQUE
Grade 8.8 bolt 600Nm

Please contact GANTRAIL, for full installation instructions.

BOLT CONFIGURATIONS

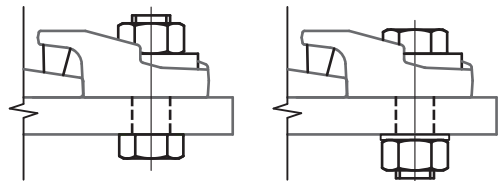

POSITIONING OF SPECIAL WASHER

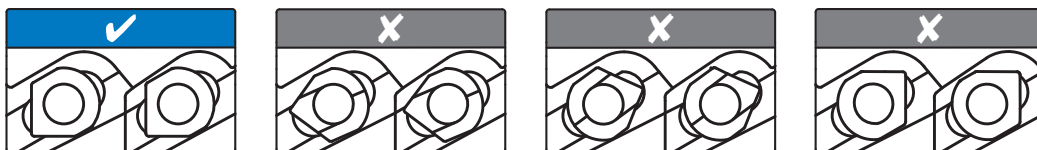

A world of crane rail expertise.

www.gantrail.com



Gantry Railing Ltd
Unit 11A
Barnett Way
Barnwood
Gloucester GL4 3QA
United Kingdom

Tel: +44 (0) 1452 300688
E-mail: info@gantrail.com



3226/15/DO/01/25