

4116/10

Gantrail Bolted Fixing

www.gantrail.com

UK patent application No GB 1912155.7



Gantrail®

A world of crane rail expertise

4116/10

The GANTRAIL 4116/10 adjustable crane rail clip is designed to fix light rails in the most arduous applications. It can withstand a horizontal force from the rail of up to 50kN (5.0 tonnes). Its low profile allows it to be used with cranes that are fitted with guide rollers.

SPECIFICATIONS:

| BOLT GRADE | 8.8 | 10.9 |
|--------------------|-----|------|
| MAX SIDE LOAD (kN) | 38 | 50 |
| BOLT TORQUE (Nm) | 200 | 300 |

10mm HORIZONTAL RAIL ADJUSTMENT

DIMENSIONS (mm):

| REF No. | X | Y (FULL NUT) | Y (THIN NUT) | Z | WEIGHT kg |
|------------|----|--------------|--------------|----|-----------|
| 4116/10/28 | 28 | 35 | 30 | 20 | 0.26 |
| 4116/10/35 | 35 | 35 | 30 | 20 | 0.27 |

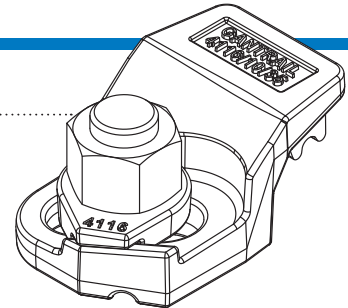

FEATURES

NEW

- Unique 'self-engaging' feature (patent pending) ensures all load bearing parts are in contact upon tightening of the bolt
- Offset washer design to ensure intuitive fool-proof installation
- Large clearance around nut to allow the use of impactor sockets
- Drain hole to prevent build up of contaminants and standing water

RETAINED

- The proven 'double-wedge' design causes self-locking and self-tightening
- The two parts are locked together upon tightening of the nut
- The clip is bolted to the rail support from above or below
- A special vulcanised rubber block applies a controlled force to the rail

COMPONENTS

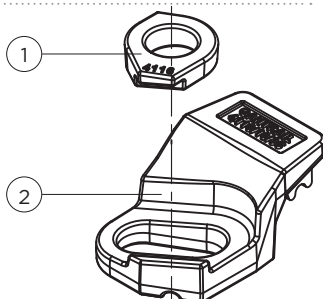

1. Special washer
2. Clip with integral rubber block

1 RAIL WITH PAD

2 RAIL WITHOUT PAD

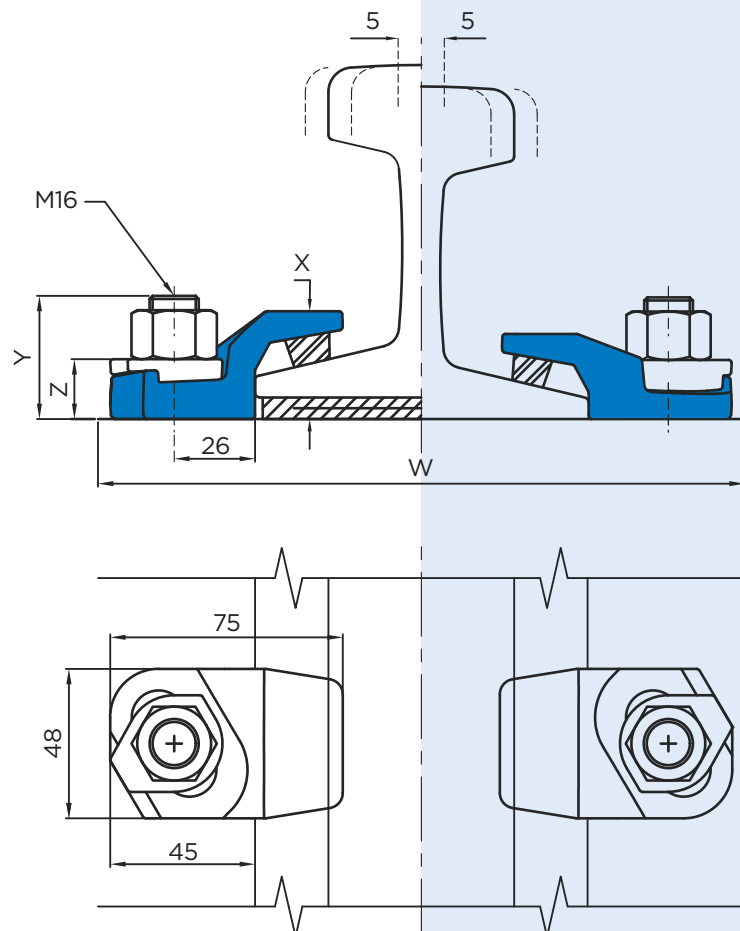

Minimum assembly width - $W = \text{Rail width (F)} + 100\text{mm}$

4116/10

Gantrail Bolted Fixing

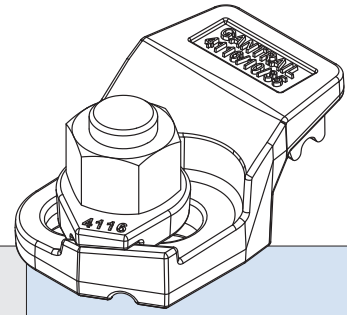

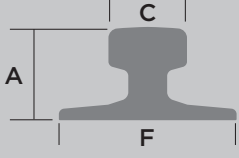
|  | F mm | C mm | A mm | 1. CLIP REFERENCE FOR RAIL WITH PAD | 2. CLIP REFERENCE FOR RAIL WITHOUT PAD |
|-----------------------------------------------------------------------------------|---------|---------|---------|----------------------------------------|-------------------------------------------|
| A 45 | 125 | 45 | 55 | 4116/10/35 | 4116/10/28 |
| A 55 | 150 | 55 | 65 | 4116/10/35 | 4116/10/28 |
| A 65 | 175 | 65 | 75 | 4116/10/35 | 4116/10/28 |
| S 14 | 70 | 38 | 80 | 4116/10/35 | 4116/10/28 |
| S 20 | 82 | 44 | 100 | 4116/10/35 | 4116/10/28 |
| S 30 | 108 | 60 | 108 | 4116/10/35 | 4116/10/28 |
| S 33 | 105 | 58 | 134 | 4116/10/35 | 4116/10/28 |
| S 41 | 125 | 67 | 138 | 4116/10/35 | 4116/10/28 |
| BS 50 '0' | 100 | 52 | 100 | 4116/10/35 | 4116/10/28 |
| AFNOR 26 | 100 | 50 | 110 | 4116/10/35 | 4116/10/28 |
| AFNOR 30 | 106 | 56 | 126 | 4116/10/35 | 4116/10/28 |
| ASCE 60 | 108 | 60 | 108 | 4116/10/35 | 4116/10/28 |
| ASCE 80 | 127 | 64 | 127 | 4116/10/35 | 4116/10/28 |
| ASCE 85 | 132 | 65 | 132 | 4116/10/35 | 4116/10/28 |
| ISCOR 22 | 95 | 50 | 95 | 4116/10/35 | 4116/10/28 |
| ISCOR 30 | 110 | 57 | 110 | 4116/10/35 | 4116/10/28 |
| JIS 22 | 93.7 | 50.8 | 93.7 | 4116/10/35 | 4116/10/28 |
| JIS 37 | 122 | 63 | 122 | 4116/10/35 | 4116/10/28 |
| JIS 40 | 122 | 64 | 140 | 4116/10/35 | 4116/10/28 |
| 15 kg.m BHP | 79 | 43 | 79 | 4116/10/35 | 4116/10/28 |
| 22 kg.m BHP | 94 | 51 | 94 | 4116/10/35 | 4116/10/28 |

This clip can be used for a wider selection of rails than illustrated. Please contact GANTRAIL for the full range of possible rails. All rails can be fastened with bolted or welded base clips. GANTRAIL may change or improve their products and also alter specifications without notice.

INSTALLATION INSTRUCTIONS:

The hexagon headed fixing bolt can be inserted from above or below the supporting structure - see adjacent configurations.

If it is desired to fix the clip with a welded stud, this may be possible. Please consult GANTRAIL for guidance.

TIGHTENING TORQUE
Grade 8.8 bolt 200Nm
Grade 10.9 bolt 300Nm

Please contact GANTRAIL, for full installation instructions.

BOLT CONFIGURATIONS

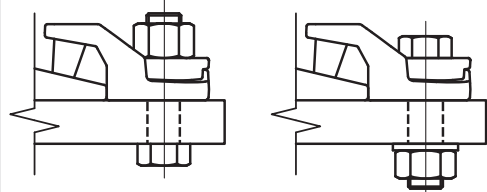

Gantrail reserve the right to improve their products and also alter specifications without notice.

Gantrail disclaim any and all liability for any errors, inaccuracies or incompleteness contained in this datasheet.

POSITIONING OF SPECIAL WASHER

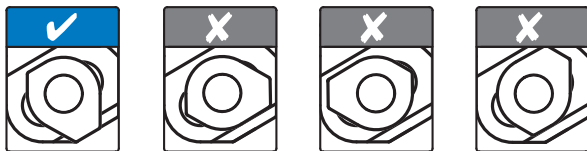

A world of crane rail expertise.

www.gantrail.com



Gantry Railing Ltd
Unit 11A
Barnett Way
Barnwood
Gloucester GL4 3QA
United Kingdom

Tel: +44 (0) 1452 300688
E-mail: info@gantrail.com



4116/10/DO/01/25