

7120/10

Gantrail Bolted Base Fixing

www.gantrail.com



Gantrail®

A world of crane rail expertise

7120/10

The GANTRAIL 7120/10 adjustable crane rail clip is designed to fix heavy rails, on narrow girders, in the most arduous applications. It can withstand a horizontal force from the rail of 75kN (7.6 tonnes). Its low profile allows it to be used with cranes that are fitted with guide rollers.

SPECIFICATIONS:

BOLT GRADE	8.8	10.9
MAX SIDE LOAD (kN)	75	100
BOLT TORQUE (Nm)	390	600

10mm HORIZONTAL RAIL ADJUSTMENT

DIMENSIONS (mm):

REF No.	X	Y (FULL NUT)	Y (THIN NUT)	Z	WEIGHT kg
7120/10/38	38	50	45	28	0.77
7120/10/48	48	60	55	38	0.98

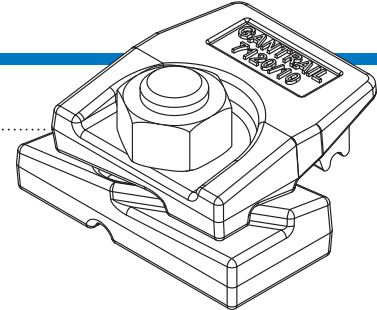

FEATURES

- The proven design has been used successfully for many years throughout the world.
- The clip is bolted to the rail support.
- The two main parts are locked together on tightening the nut.
- A special vulcanised rubber block applies a controlled force to the rail.

COMPONENTS

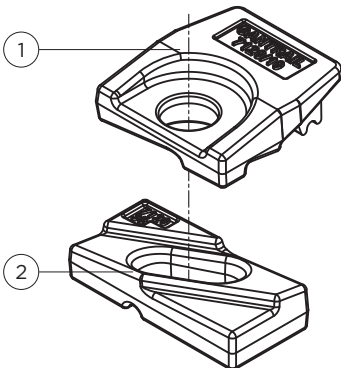

1. Clip cap with integral rubber block
2. Clip base

1 RAIL WITH PAD

2 RAIL WITHOUT PAD

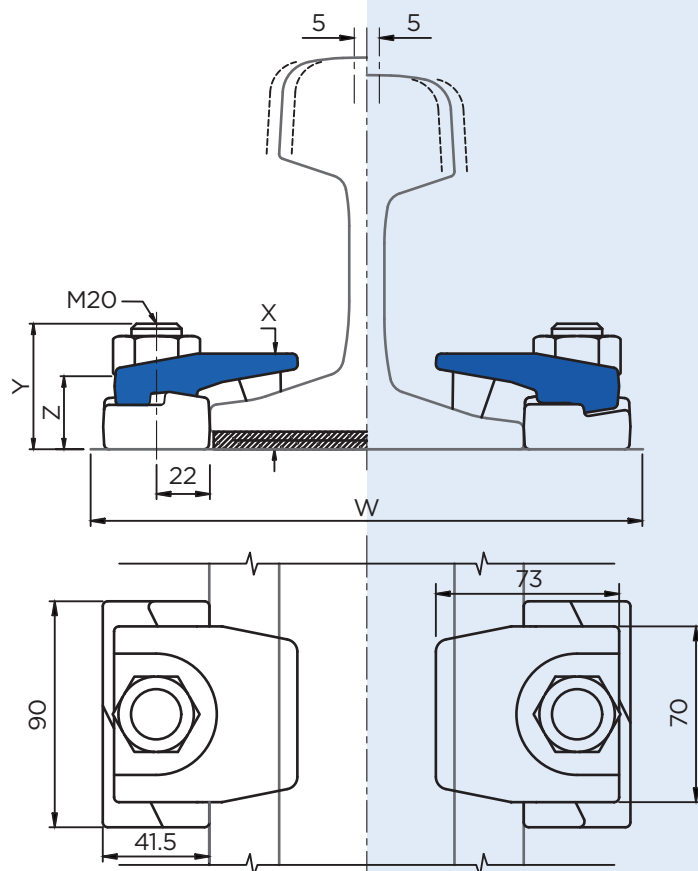

Minimum assembly width - W = Rail width (F) + 95mm

7120/10

Gantrail Bolted Base Fixing

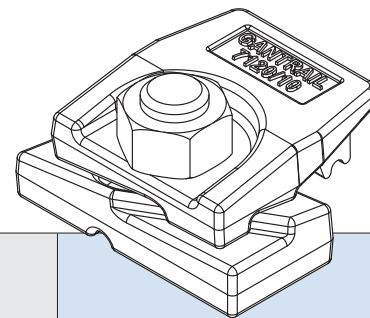

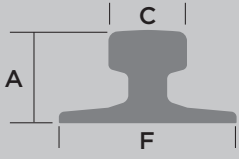
	F mm	C mm	A mm	1. CLIP REFERENCE FOR RAIL WITH PAD	2. CLIP REFERENCE FOR RAIL WITHOUT PAD
A 65	175	65	75	7120/10/38	7120/10/38
A 75	200	75	85	7120/10/38	7120/10/38
A 100	200	100	95	7120/10/38	7120/10/38
S 33	105	58	134	7120/10/38	7120/10/38
S 41	125	67	138	7120/10/38	7120/10/38
S 49	125	67	149	7120/10/38	7120/10/38
56 E 1	140	70	159	7120/10/38	7120/10/38
ISCR 50	90	50	90	7120/10/38	7120/10/38
ISCR 60	105	60	105	7120/10/38	7120/10/38
ISCR 80	130	82	130	7120/10/38	7120/10/38
QU 70	120	70	120	7120/10/38	7120/10/38
QU 80	130	80	130	7120/10/38	7120/10/38
JIS 37	122	63	122	7120/10/38	7120/10/38
JIS 40	122	64	140	7120/10/38	7120/10/38
41 kg AS	127	64	137	7120/10/38	7120/10/38
50 kg AS	127	70	157	7120/10/38	7120/10/38
53 kg AS	146	70	157	7120/10/38	7120/10/38
UIC 54	140	70	159	7120/10/38	7120/10/38
UIC 60	150	72	172	7120/10/38	7120/10/38

This clip can be used for a wider selection of rails than illustrated.

Please contact GANTRAIL for the full range of possible rails. All rails can be fastened with bolted or welded base clips. GANTRAIL may change or improve their products and also alter specifications without notice.

INSTALLATION INSTRUCTIONS:

The hexagon headed fixing bolt can be inserted from above or below the supporting structure – see adjacent configurations.

If it is desired to fix the clip with a welded stud, this may be possible. Please consult GANTRAIL for guidance.

TIGHTENING TORQUE
Grade 8.8 bolt 390Nm
Grade 10.9 bolt 600Nm

Please contact GANTRAIL, for full installation instructions.

BOLT CONFIGURATIONS

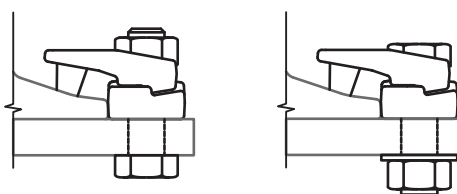

WELD RECESS FOR STUD WELDING

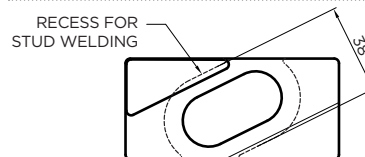

A world of crane rail expertise.

www.gantrail.com



Gantry Railing Ltd
Unit 11A
Barnett Way
Barnwood
Gloucester GL4 3QA
United Kingdom

Tel: +44 (0) 1452 300688
E-mail: info@gantrail.com



7120/10/DO/01/25