

2 Series Clips

Fitting Instructions

These instructions to be read in conjunction with product datasheet, available from www.gantrail.com.

FIGURE 1

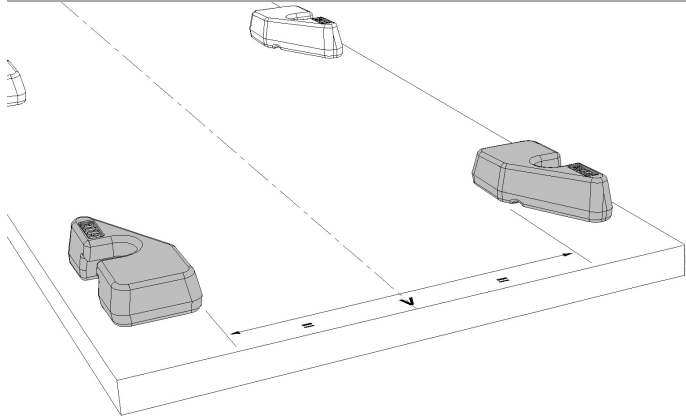

Mark out and position clip base across rail centreline according to 'V' dimension on product datasheet. Position of clip base along rail, to suit project requirements or consult GANTRAIL.

FIGURE 2

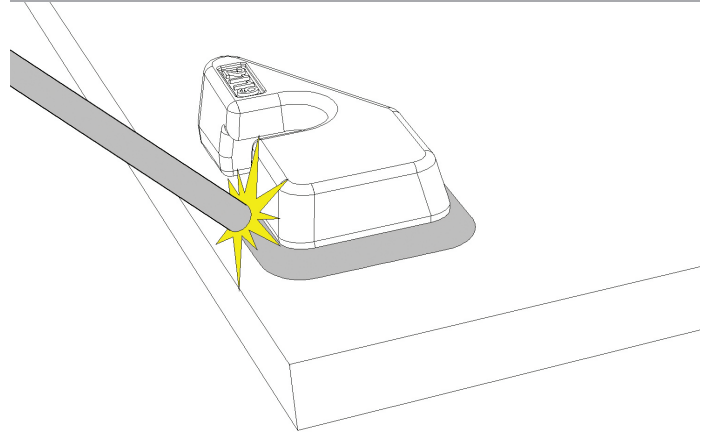

NOTE: Tack weld ends and front face prior to welding. Using suitable electrode, weld clip base(s) to rail support according to 'WELD DETAIL' on product datasheet.

FIGURE 3

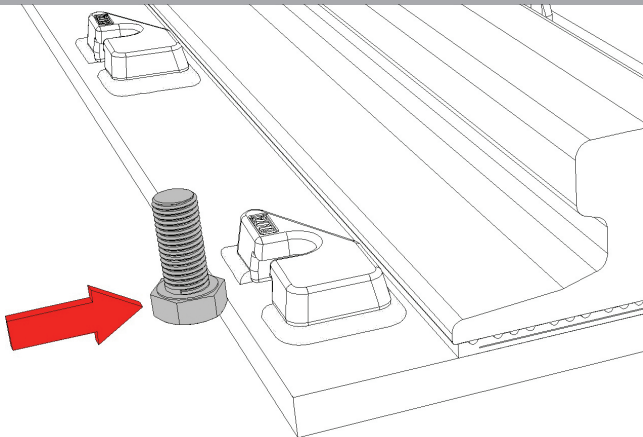

With rail and pad in position, insert hexagon headed bolt into clip base and move into final position.

FIGURE 4

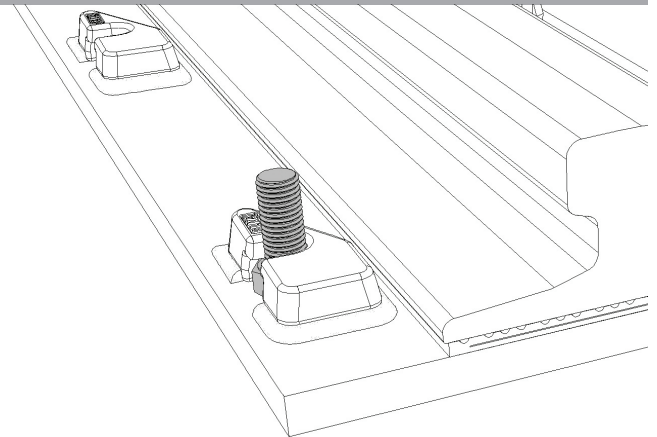

In final position, bolt(s) will be snug in semi-circular hole(s).

FIGURE 5

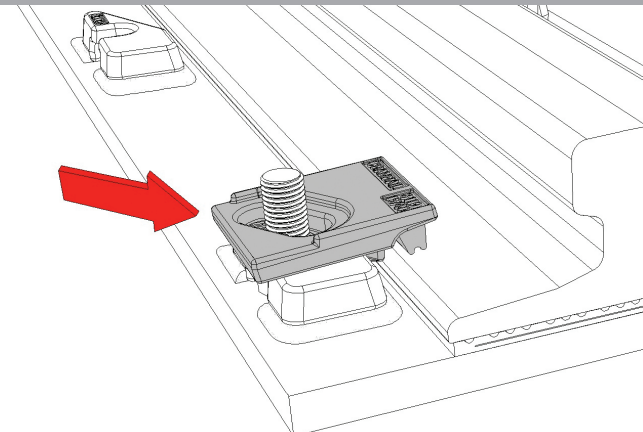

Place clip top over bolt(s) with rubber 'nose' resting on upper surface of bottom flange of rail. Move clip top into metal-to-metal contact with bottom edge of rail.

FIGURE 6

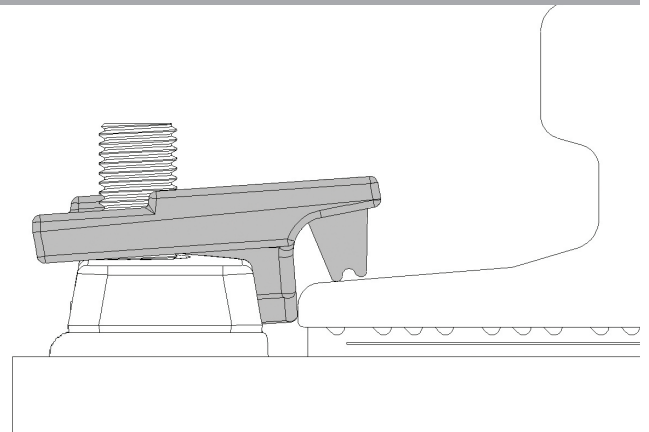

Bottom surface of clip top will not be in full metal-to-metal contact with clip base.

FIGURE 7

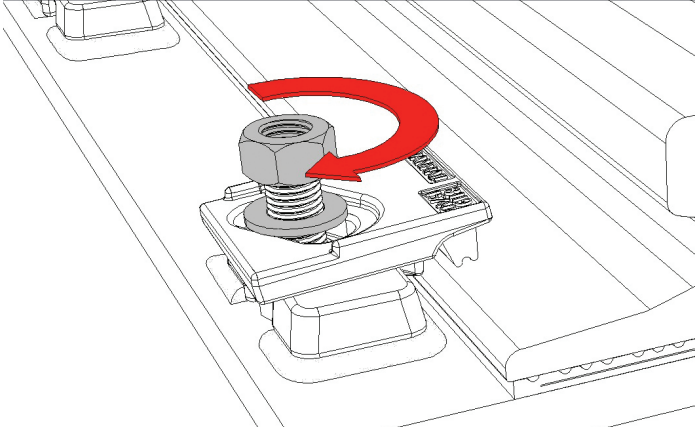

Place washer(s) over bolt(s) and run nut(s) down bolt(s).

FIGURE 8

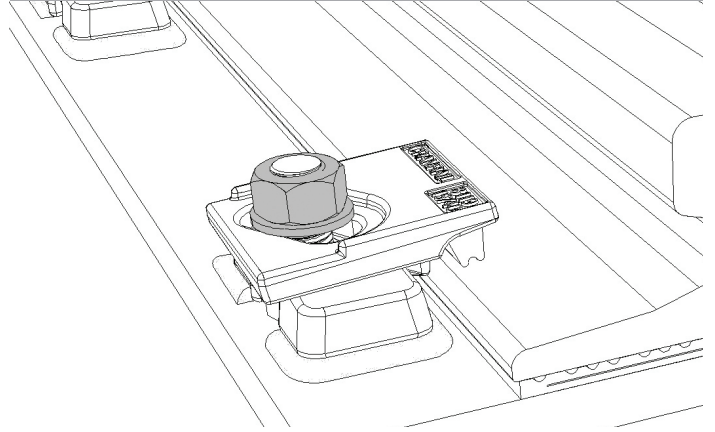

Nut(s) to make contact with washer(s).

FIGURE 9

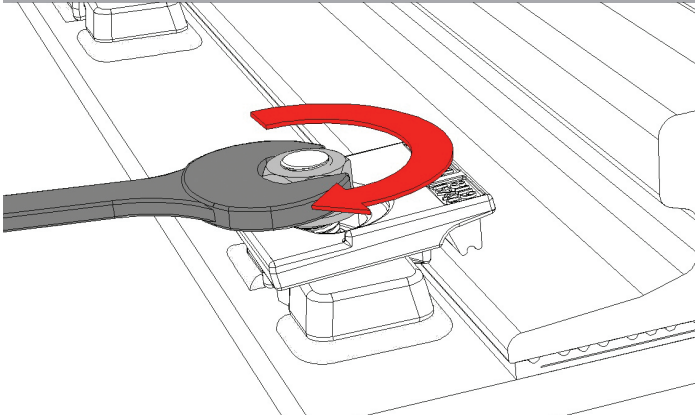

Tighten nut(s) with spanner.

FIGURE 10

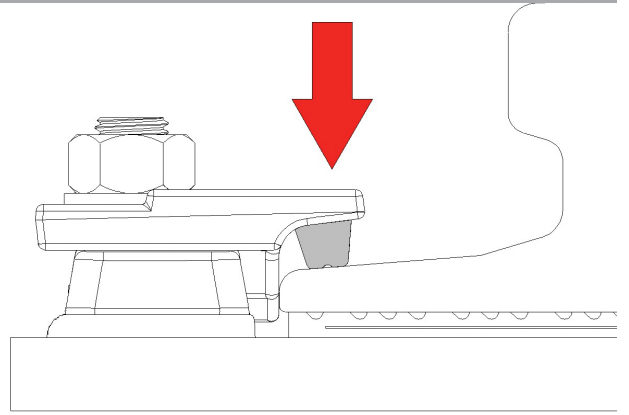

Tighten only until rubber 'nose' is compressed and bottom surface of clip top is in full metal-to-metal contact with clip base. Do not apply full torque yet.

FIGURE 11

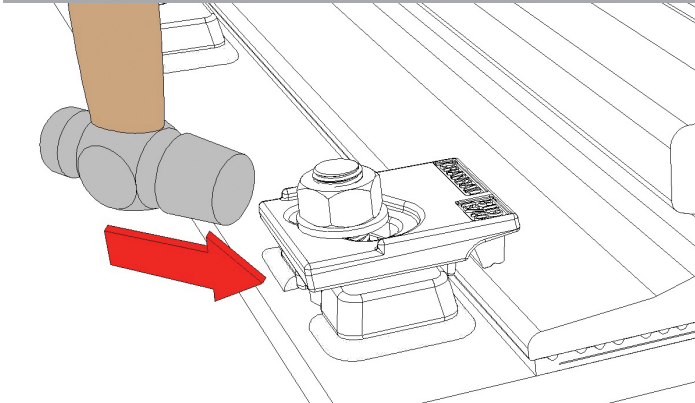

With hammer of about 1 kilo, tap clip top towards rail along direction of slot(s) in clip top.

FIGURE 12

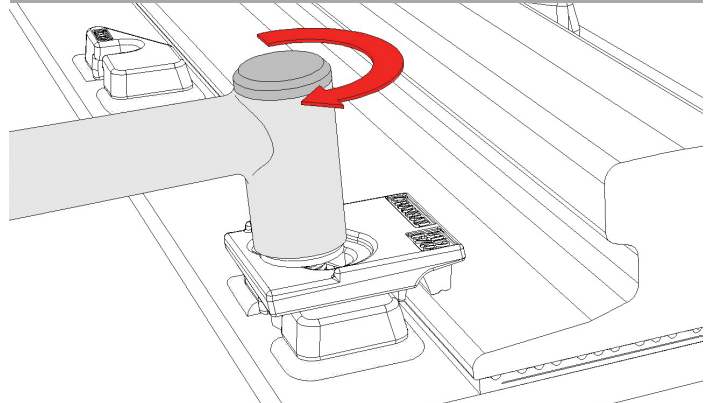

Tighten nut(s) to required torque given on clip datasheet.

A world of crane rail expertise.

www.gantrail.com



Gantry Railing Ltd
 Unit 11A
 Barnett Way
 Barnwood
 Gloucester GL4 3QA
 United Kingdom

Tel: +44 (0) 1452 300688
 E-mail: info@gantrail.com

