

3 Series Clips

Fitting Instructions

These instructions to be read in conjunction with product datasheet, available from www.gantrail.com.

FIGURE 1

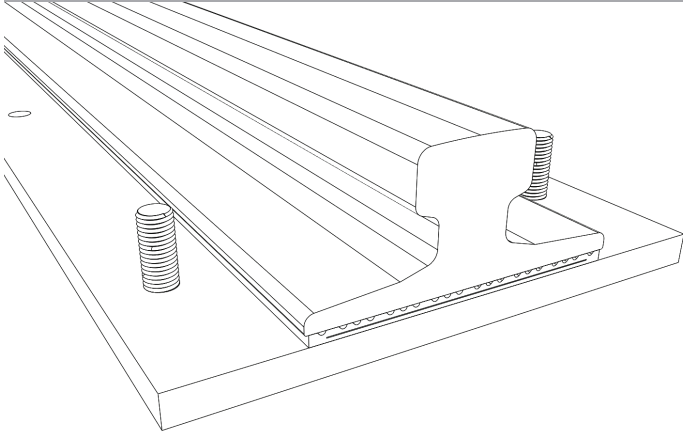

Insert bolt(s) through hole(s) in rail supporting structure.

FIGURE 2

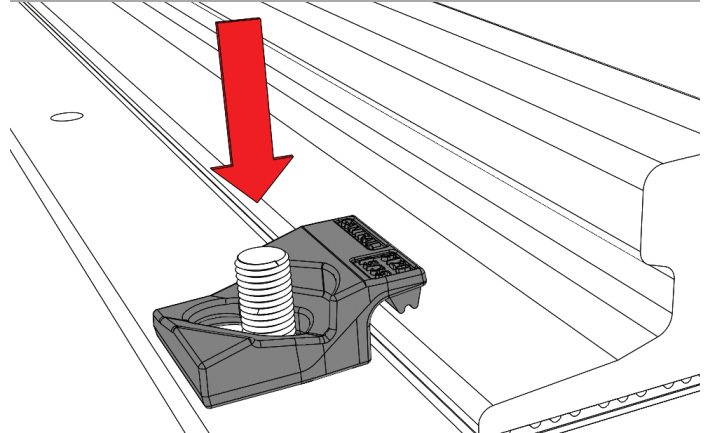

Place body of clip over bolt(s) with rubber 'nose' resting on upper surface of bottom flange of rail.

FIGURE 3

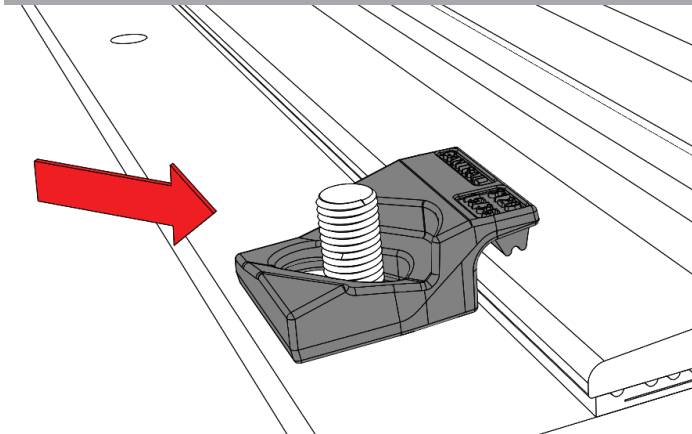

Move clip into metal-to-metal contact with bottom edge of rail.

FIGURE 4

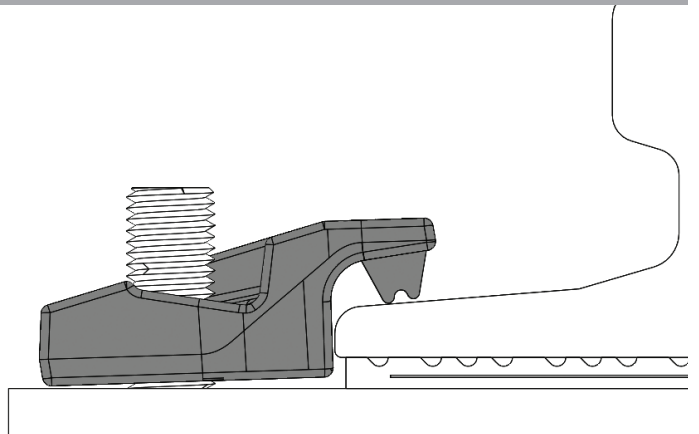

Bottom face of clip will not be in full contact with rail support.

FIGURE 5

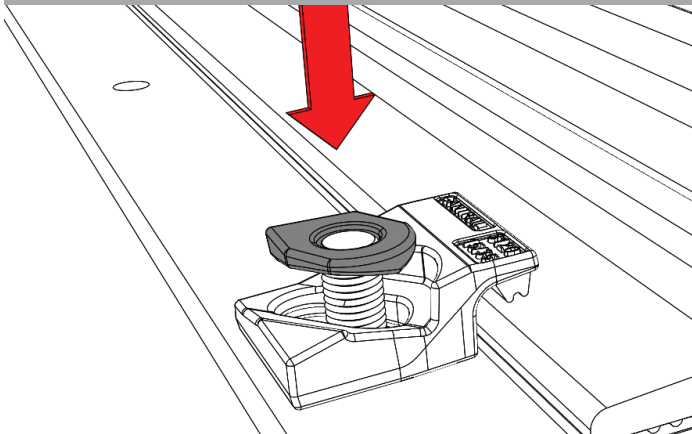

Place special washer(s) over bolt(s).

FIGURE 6

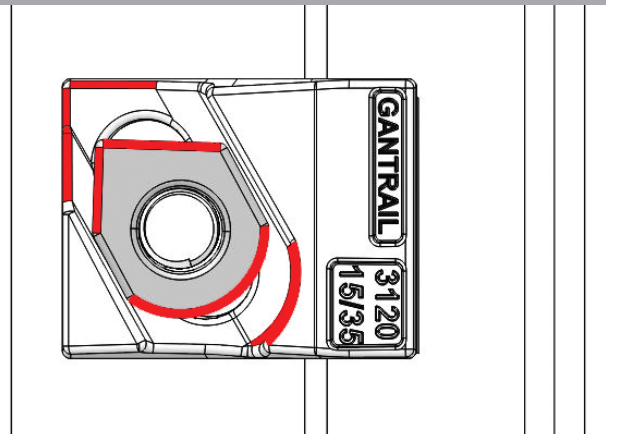

Make sure special washer(s) is fitted correctly with square corner to back and flat surface upwards.

FIGURE 7

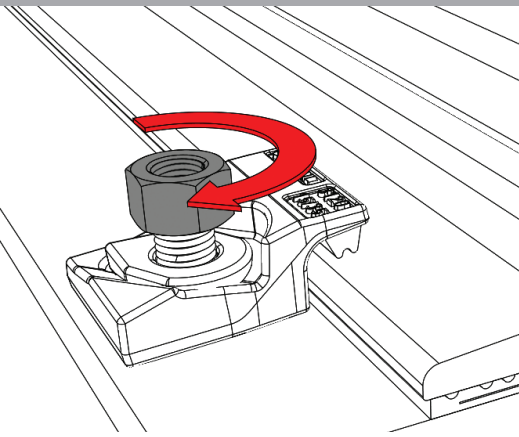

Run nut(s) down bolt(s).

FIGURE 8

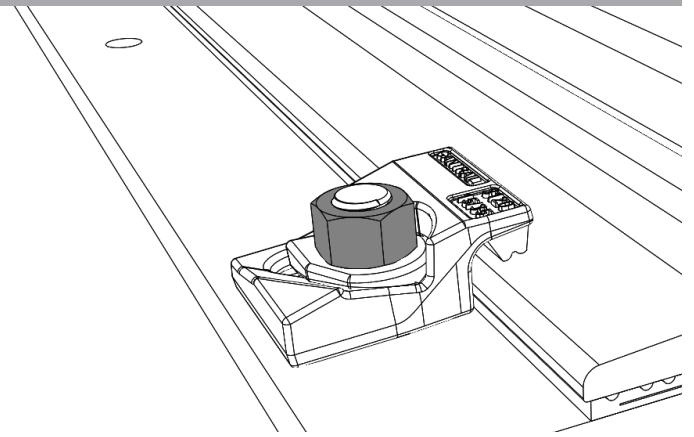

Nut(s) to make contact with special washer(s).

FIGURE 9

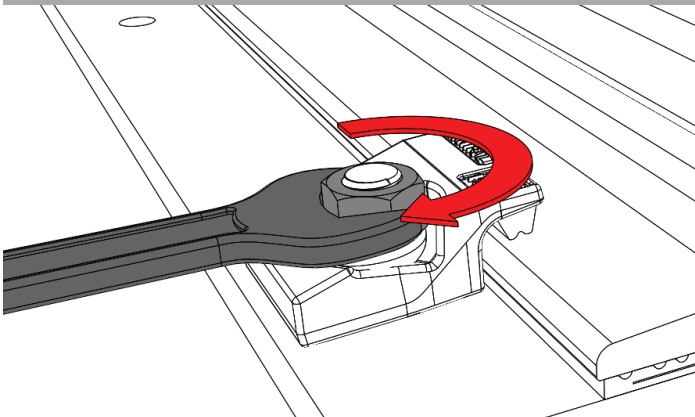

Tighten nut(s) with spanner.

FIGURE 10

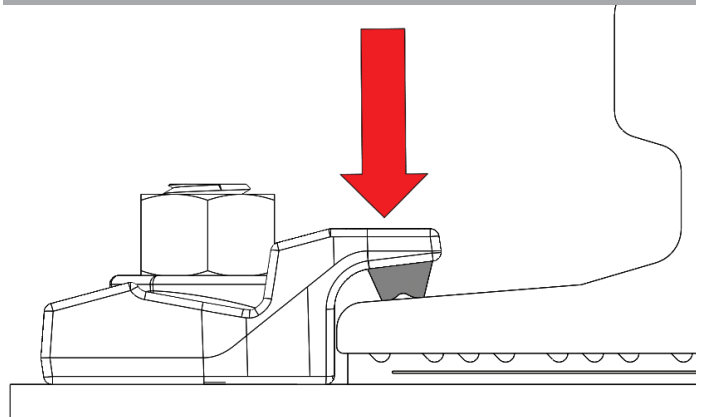

Tighten only until rubber 'nose' is compressed and bottom surface of clip is in full metal-to-metal contact with rail support. Do not apply full torque yet.

FIGURE 11

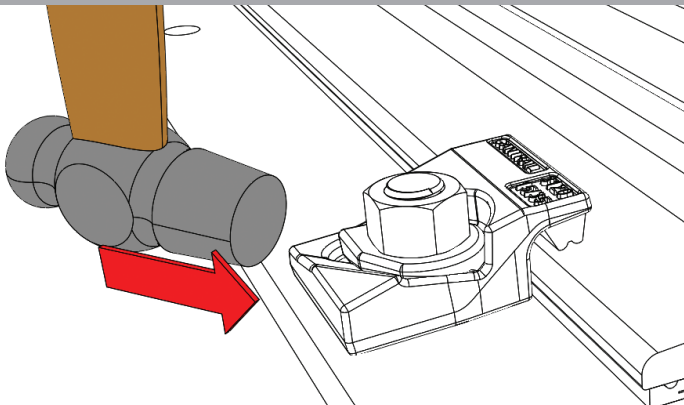

With hammer of about 1 kilo, tap clip body towards rail along direction of slot(s) in clip.

FIGURE 12

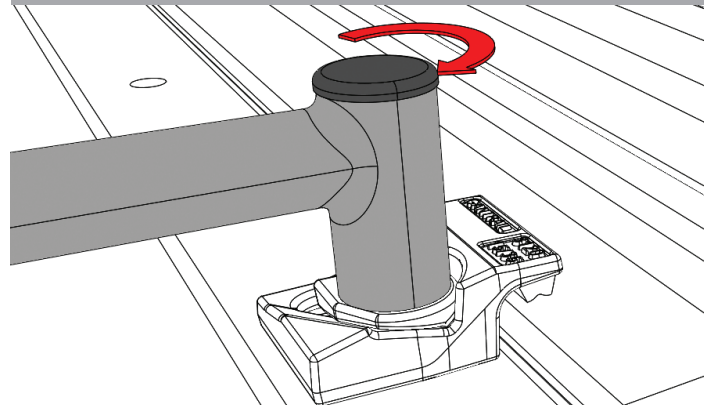

Tighten nut(s) to required torque given on product datasheet.

A world of crane rail expertise.

www.gantrail.com



Gantry Railing Ltd
 Unit 11A
 Barnett Way
 Barnwood
 Gloucester GL4 3QA
 United Kingdom

Tel: +44 (0) 1452 300688
 E-mail: info@gantrail.com

