

6 Series Clips

Fitting Instructions

These instructions to be read in conjunction with product datasheet, available from www.gantrail.com.

FIGURE 1

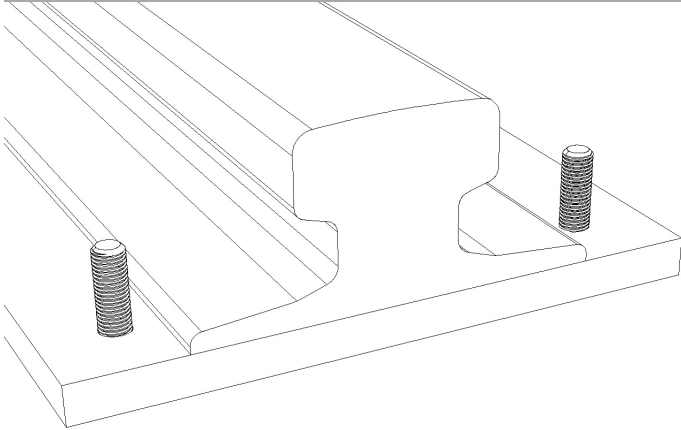

Insert bolt through hole in rail supporting structure.

FIGURE 2

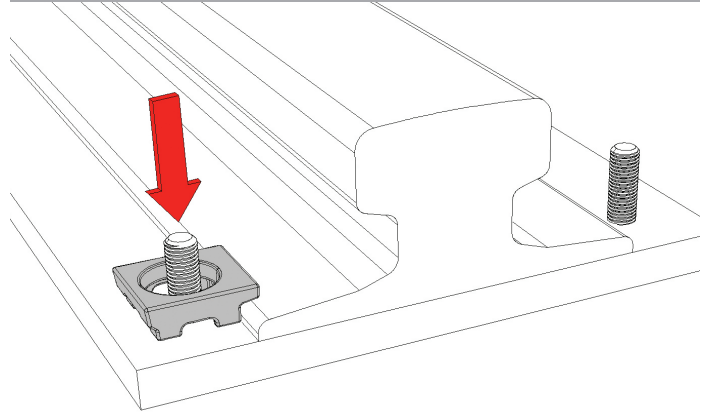

Place clip body over bolt.

FIGURE 3

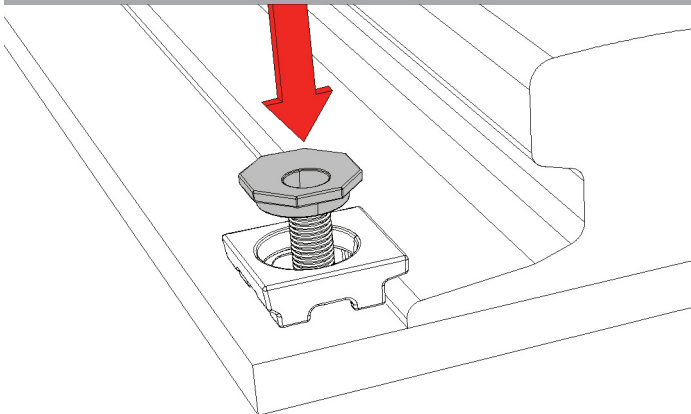

Place cam washer over bolt.

FIGURE 4

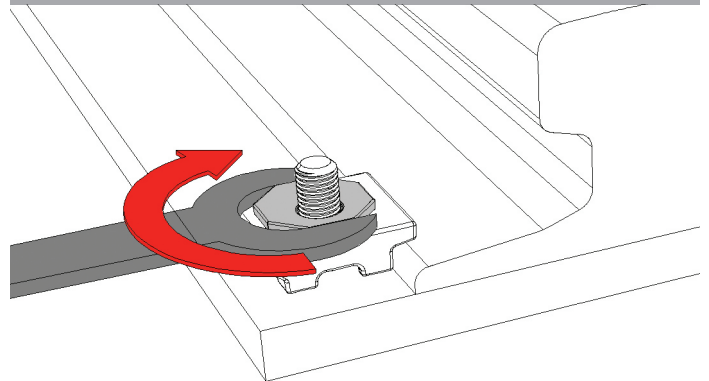

Using C Spanner to rotate cam washer to move clip into metal to metal contact with bottom edge of rail.

FIGURE 5

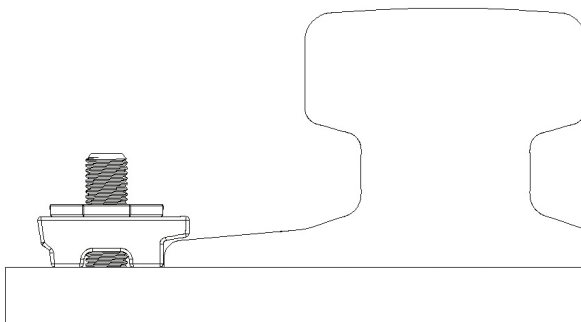

Clip in metal to metal contact with bottom edge of rail.

FIGURE 6

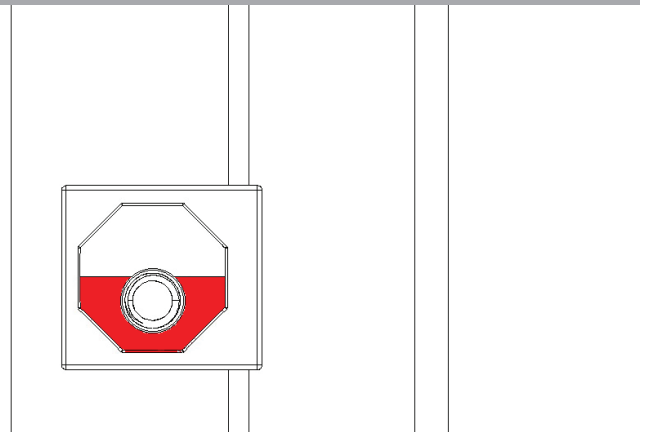

IMPORTANT: Ensure bolt is positioned in the right hand half of the cam washer.

FIGURE 7

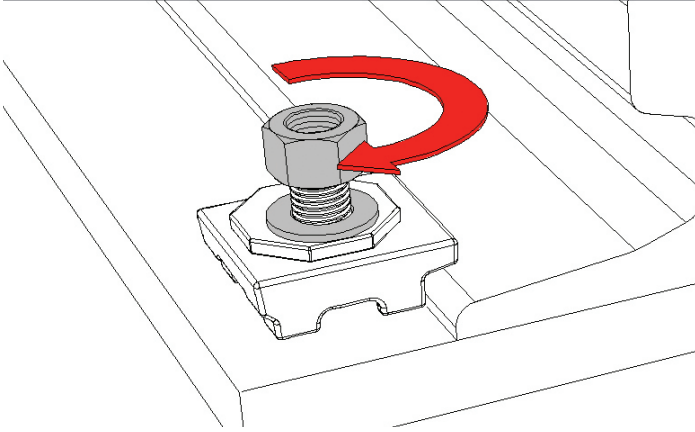

Place washer over bolt and run nut down bolt.

FIGURE 8

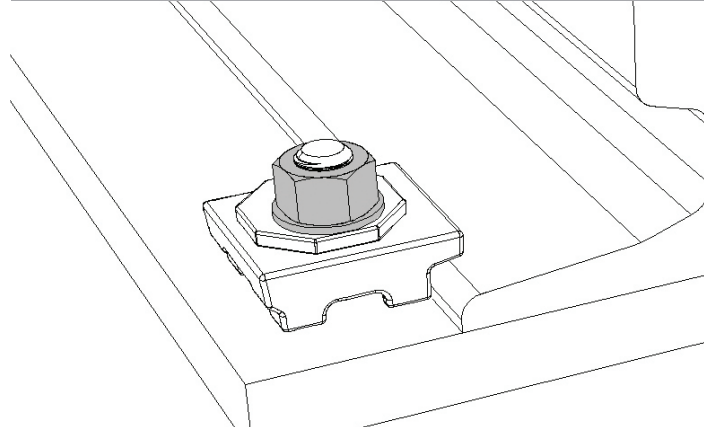

Nut to make full contact with washer.

FIGURE 9

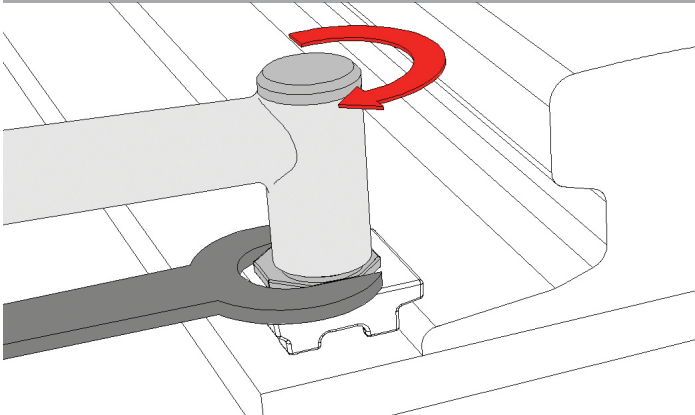

Hold clip in position with C spanner, tighten nut to required torque given on clip datasheet.

A world of crane rail expertise.

www.gantrail.com



Gantry Railing Ltd
Unit 11A
Barnett Way
Barnwood
Gloucester GL4 3QA
United Kingdom

Tel: +44 (0) 1452 300688
E-mail: info@gantrail.com

