

7 Series Clips

Fitting Instructions

These instructions to be read in conjunction with product datasheet, available from www.gantrail.com.

FIGURE 1

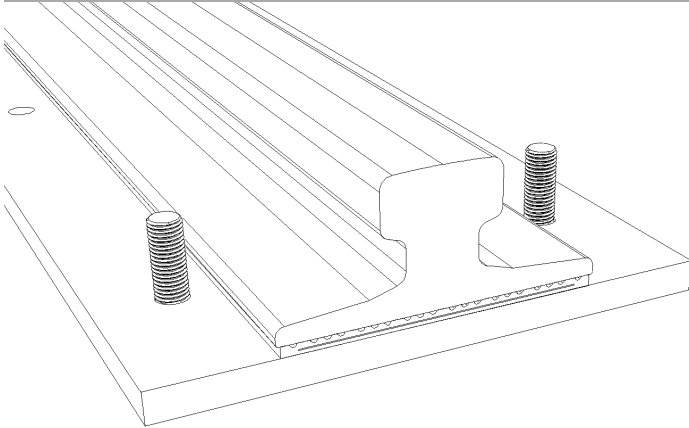

Insert bolt(s) through hole(s) in rail supporting structure.

FIGURE 2

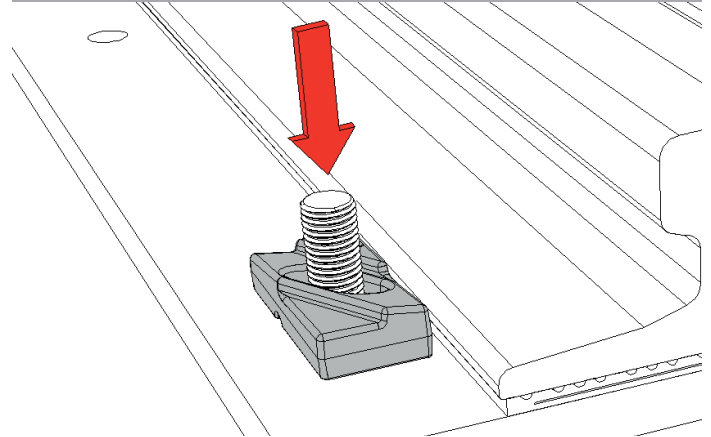

Place body of clip base over bolt.

FIGURE 3

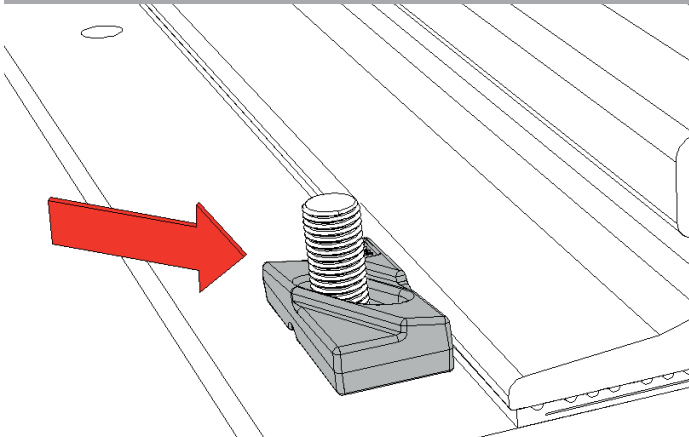

Move clip base into metal-to-metal contact with bottom edge of rail.

FIGURE 4

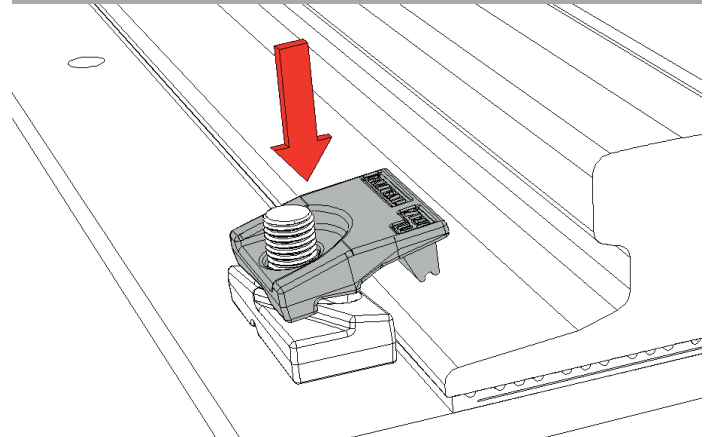

Place clip top over bolt with rubber 'nose' resting on upper surface of bottom flange of rail.

FIGURE 5

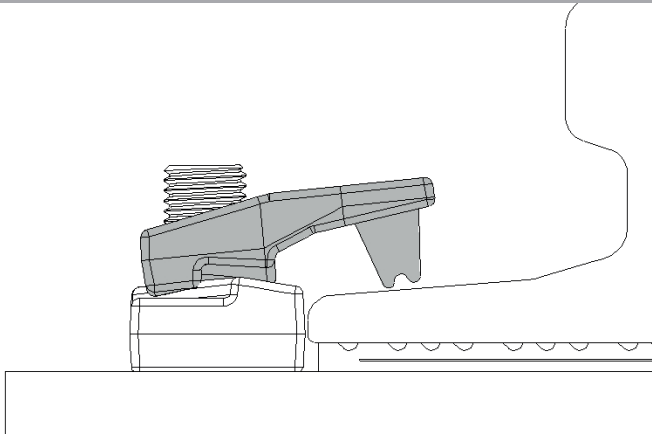

Bottom surface of clip top will not be in full metal-to-metal contact with clip base.

FIGURE 6

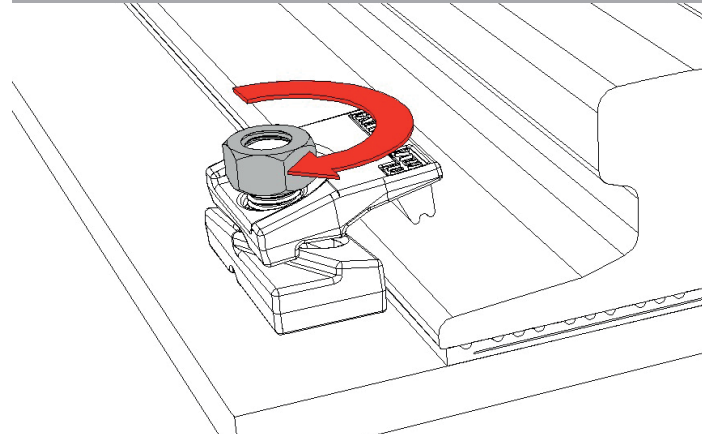

Run nut down bolt.

FIGURE 7

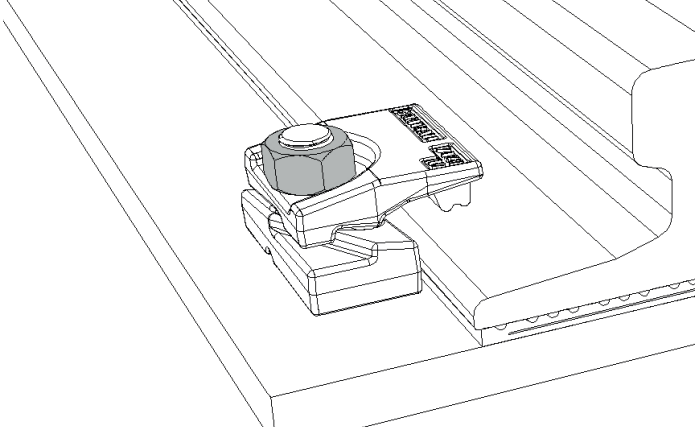

Nut to make contact with clip top.

FIGURE 8

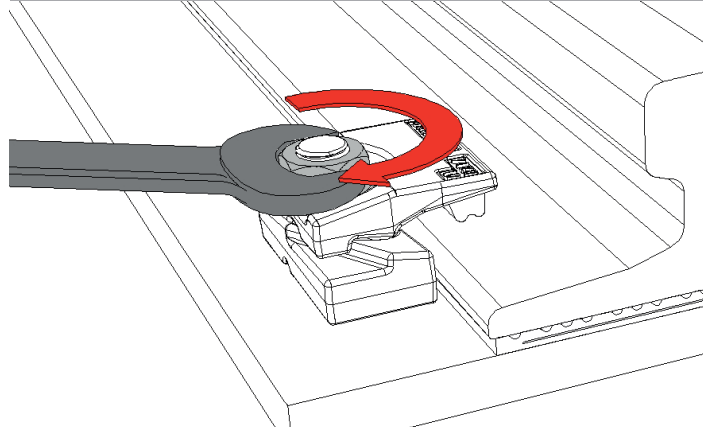

Tighten nut with spanner.

FIGURE 9

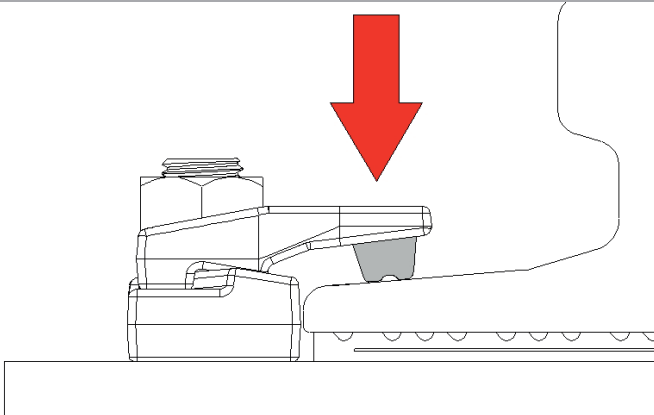

Tighten only until rubber 'nose' is compressed and bottom surface of clip top is in full metal-to-metal contact with clip base. Do not apply full torque yet.

FIGURE 10

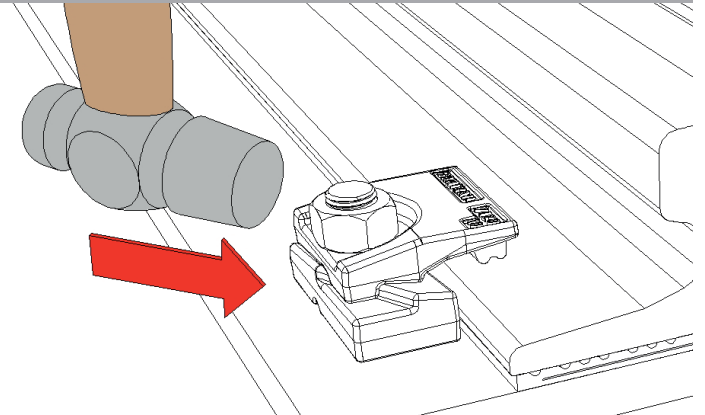

With hammer of about 1 kilo, tap clip base towards rail along direction of slot in clip.

FIGURE 11

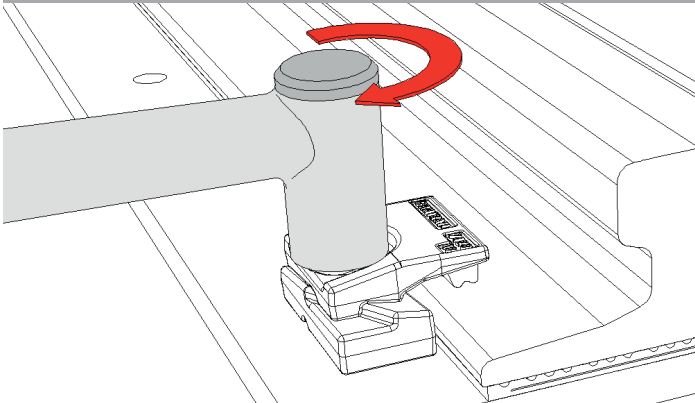

Tighten nut to required torque given on product datasheet.

A world of crane rail expertise.

www.gantrail.com



Gantry Railing Ltd
 Unit 11A
 Barnett Way
 Barnwood
 Gloucester GL4 3QA
 United Kingdom

Tel: +44 (0) 1452 300688
 E-mail: info@gantrail.com

