

Mark 5

Gantrail Resilient Pad For Continuous Rail Support

www.gantrail.com



The use of Gantrail Mark 5 Crane Rail Pad between a rail and its support improves the performance of crane tracks. Cranes apply high forces to the structures on which they are mounted. The pad significantly reduces the stress between the rail and its support. The Gantrail pad is one of the three key ingredients in achieving a reliable track. These are:-

- Resilient Pad
- Strong, adjustable clips
- Continuously welded rail

SPECIFICATIONS:

The pad width should be nominally 5mm less than the rail foot width.

DIMENSIONS:

PART No	W mm (Flat)
MK5-098	98

Gantrail flat pad is normally supplied in 12 metre lengths of the width shown but is also available in lengths and widths to suit customer specification. This may result in longer lead times -Please contact GANTRAIL for guidance.

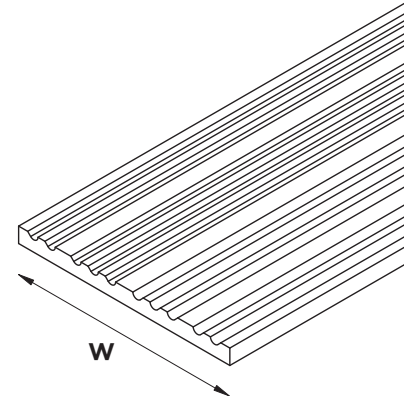

Mark 5

FEATURES

The Gantrail pad has been designed with a fluted top surface. This results in a two stage stiffness characteristic. On loading, the voids in the top allow the Gantrail clips to pre-compress the pad a small amount. On increasing the wheel loading, the voids are filled and the pad becomes stiffer. This ensures that the rail is not over stressed.

CONTINUOUS SUPPORT

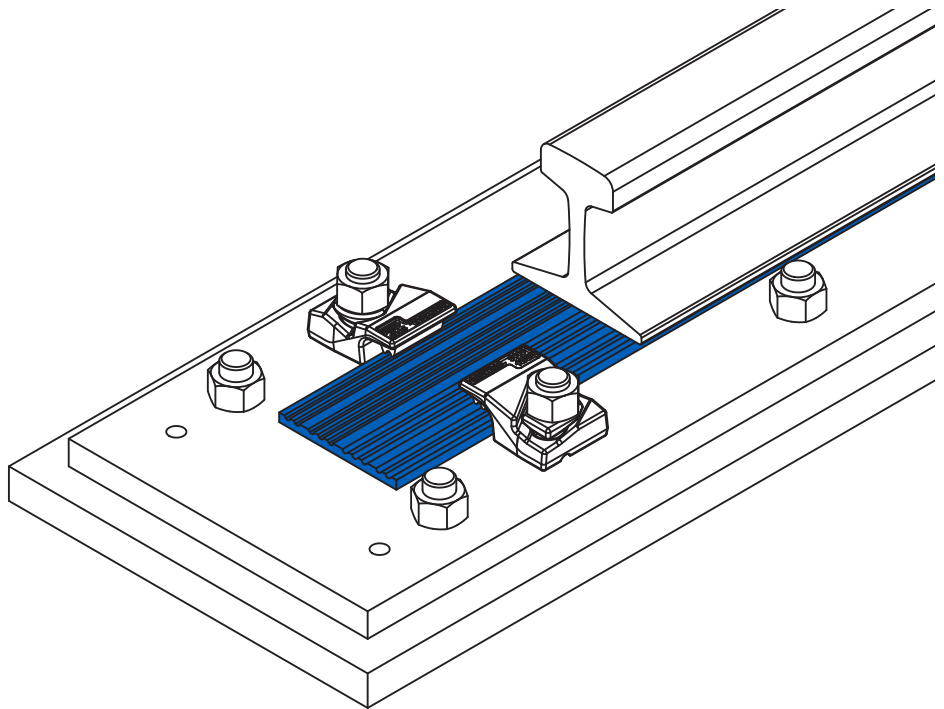

Gantrail can supply standard design details and technical information in support of all crane rail applications.

Mark 5

Gantrail Resilient Pad For Continuous Rail Support

Gantrail Mark 5 pads are manufactured from wear resistant durable vulcanised nitrile rubber. They are unaffected by oil, grease or ultraviolet light. They have been tested to many times the design loads and show complete recovery.

TYPICAL PROPERTIES

		After Ageing
Material	Nitrile rubber	
Shore hardness (ISO 48:1994)	75 ± 5 IRHD	75 ± 5 IRHD
Tensile strength (ISO 37:1994)	17.5 N/mm ²	15 N/mm ²
Elongation (ISO 37:1994)	305%	240%
Compression set (ISO 815:1991)	5% Max @ 23°C	
Rebound resilience (ISO 4662:1986)	27%	
Temperature range	-25°C to 100°C	

Note: Typical properties shown, but actual properties may vary according to batch. Gantrail will supply pad suitable for the intended loads and application.

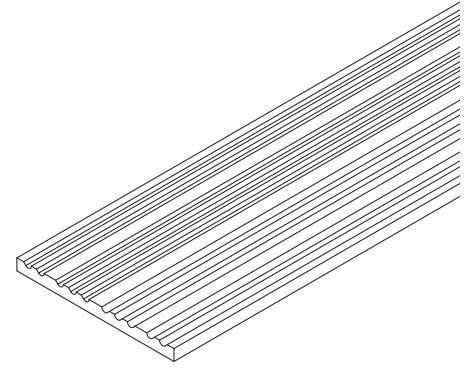

PAD FOR CONTINUOUSLY SUPPORTED APPLICATIONS

Gantrail 'flat' pad is suitable for all applications where soft mounting is desirable. Historically, pad was provided 1.5mm thicker at the centre than the edges due to the concave shape of the base of some rails. It has been shown that there is no significant benefit in using this 'crowned' pad.

STIFFNESS CHARACTERISTICS

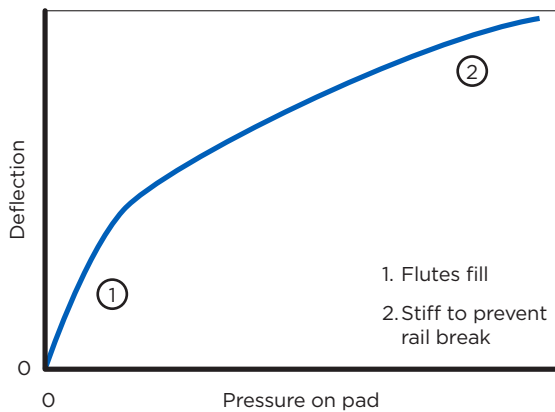

MARK 5 PROFILE

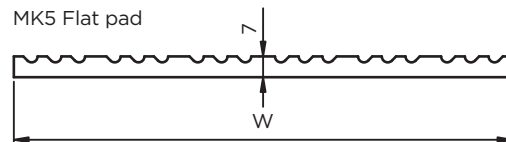

INSTALLATION INSTRUCTIONS:

Rail pad should be narrower than the rail it is supporting (nominally 5mm). The pad is normally supplied in 12 metre lengths. The flutes of the pad are placed facing upwards. The pad may be cut to precise length of rail. It can be cut with a hacksaw or jigsaw. No installed length of pad should be less than the spacing between three pairs of crane rail fixing clips. Before installing Mark 5 pad, the supporting area should be clean and free of oil, grease or any projections likely to damage the pad. It is preferable that the steel structure below the pad is not painted. If the rail is to be welded the pad should be protected from excessive heat during welding by being removed under the weld or by being protected with a thermal barrier. Our technical department will be pleased to advise on the suitability of Mark 5 pad in specific installation conditions.

Gantrail reserves the right to make, from time to time, such departures from the detail specifications as may be required to permit improvements in the design of its products and to allow the use of batches of material that fulfil the loading requirements of the intended application. The information included herein is believed to be accurate and reliable. However, Gantrail assumes no responsibility for its use; nor for any infringements of patents or other rights of third parties which may result from its use.

A world of crane rail expertise.

www.gantrail.com



Gantry Railing Ltd
Unit 11A
Barnett Way
Barnwood
Gloucester GL4 3QA
United Kingdom

Tel: +44 (0) 1452 300688
E-mail: info@gantrail.com



Mark 5 Resilient Pad/DO/01/25