

# Gantrail® Crane Rail Welding

Consumables and equipment for aluminothermic crane rail weld

[www.gantrail.com](http://www.gantrail.com)

**RAILTECH-PLÖTZ**



**Gantrail® promote the use of continuously welded crane rails. This is most important for the efficient and trouble free operation of medium and heavy duty cranes. Crane rails are made from high carbon and alloy content steel and cannot be welded by conventional shop welding techniques. This data sheet gives details of the consumables needed to weld rails by the aluminothermic process. It should be read in conjunction with the relevant procedures.**



The benefits for continuously welded rail are considerable but they require the rail to be welded on site. Most crane rails are supplied in lengths of 12 metres. Typically rails may be welded into lengths of 300 metres or more with no expansion joint. The rail cross sections are large and the metallurgy; with high carbon and manganese content; make welding difficult.

Several methods have been developed that can readily be used. Aluminothermic rail welding is well established and is the most commonly used process for site welding of railway rails in many parts of the world. It is equally applicable to the site welding of crane rails.

## METHOD

The rail ends are left cut square and set a distance apart. The volume around the ends is enclosed with a refractory mould and sealed. The mould is supported by reusable tooling. The gap between the two rails and the mould are preheated with the prescribed burner for the required time. Then the disposable crucible is placed above the rail and it is ignited. The casting process from then on is automatic. After a set time the tooling, the remains of the mould and excess metal of the runners and risers are removed.

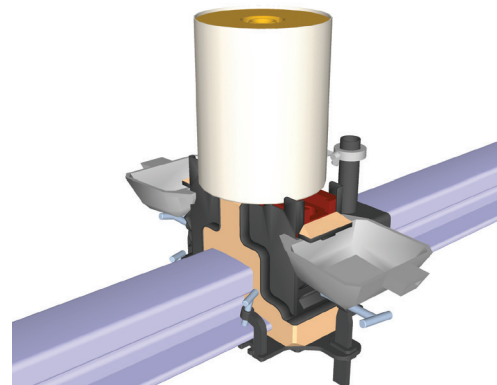

The arrangement for welding. The refractory sand mould is held in place around the rail with clamps. The disposable crucible is protected in a cardboard tube. Excess slag from the casting process flows into the slag pans.

# Gantrail® Crane Rail Welding

Consumables and equipment for aluminothermic crane rail welding

## NECESSARY WELDING EQUIPMENT & CONSUMABLES

### NECESSARY SPECIAL EQUIPMENT

The following welding equipment is required.

A full set of specialist equipment is required to carry out welding process. This does not include equipment for shearing off excess metal or reforming the head of the rail by grinding. Gantrail can advise on these processes and the equipment required.

- Rail space setting gauge
- DIN-straight edge, 1 metre
- Short and long wedges
- Mould files
- Universal clamp and mould clamps
- Crucible fork
- Slag pans
- Preheat burner and holding device
- Regulators, flash back arrestor and hoses for propane and oxygen
- Thermometer magnetic clamp
- Hot chisel.

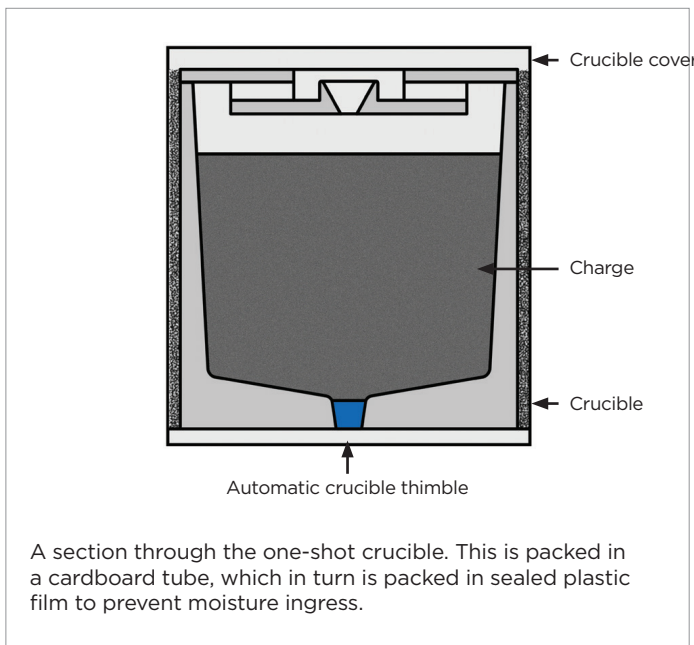

### NECESSARY CONSUMABLES REQUIRED

The following welding consumables are required for each weld.

- Welding charges in one-shot crucible suitable for the crane rail profile and rail grade
- Welding moulds suitable to the crane rail profile (three parts, one bottom and two sides.)
- Paste and/or luting sand for sealing the moulds
- Starter to ignite the crucible
- Sufficient oxygen and propane for the preheating burner.

### WELDING

The welding should be completed by personnel trained in the use of this brand of aluminothermic welding materials. There are differences between the different makers materials and procedures. The process should follow the appropriate instructions and with regard to the required safety measures.

Information and diagrams are reproduced with permission of Rolf Plötz GmbH & Co. KG

A world of crane rail expertise.

[www.gantrail.com](http://www.gantrail.com)



**Gantry Railing Ltd**  
Unit 11A  
Barnett Way  
Barnwood  
Gloucester GL4 3QA  
United Kingdom

Tel: +44 (0) 1452 300688  
E-mail: [info@gantrail.com](mailto:info@gantrail.com)



Crane Rail Welding/DO/01/25