

6124/20C

Gantrail Bolted Fixing

www.gantrail.com



6124/20C

The GANTRAIL 6124/20C adjustable crane rail clip is designed to fix heavy rails in the most arduous applications. It can withstand a horizontal force from the rail of 125kN (12.7 tonnes). Its low profile allows it to be used with cranes that are fitted with guide rollers.

SPECIFICATIONS:

BOLT GRADE	8.8
MAX SIDE LOAD (kN)	125

20mm HORIZONTAL RAIL ADJUSTMENT

DIMENSIONS (mm):

REF No.	X	Y (FULL NUT)	Y (THIN NUT)	Z	WEIGHT kg
6124/20C/26	26	65	55	35	0.84

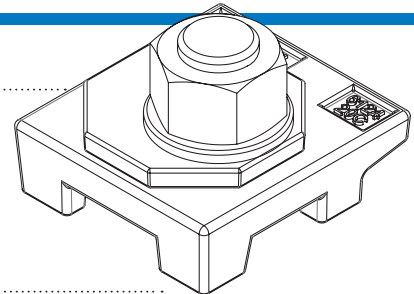

FEATURES

- The proven design has been used successfully for many years throughout the world.
- The clip is bolted to the rail support.
- The two main parts are locked together on tightening the nut.

COMPONENTS

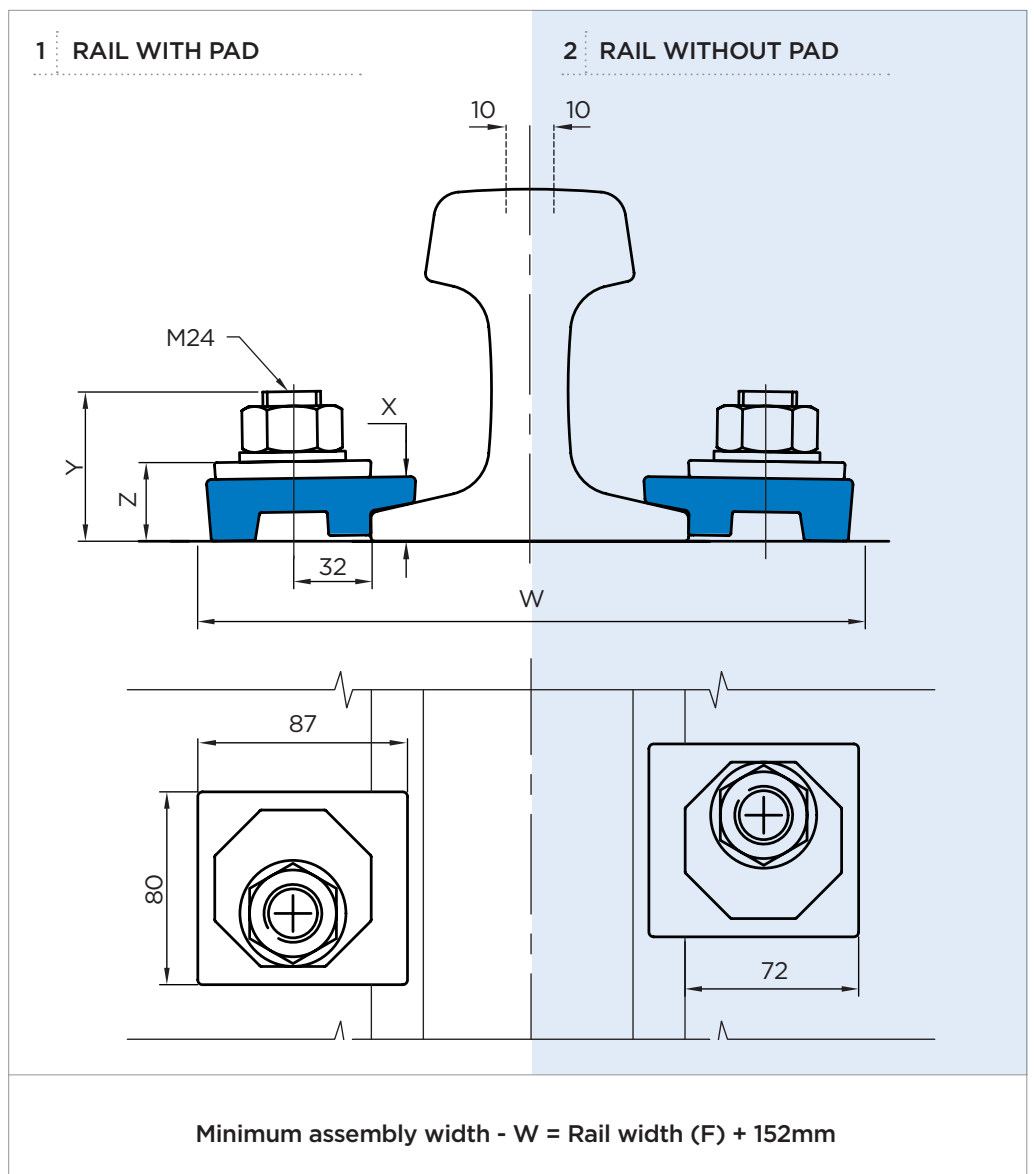
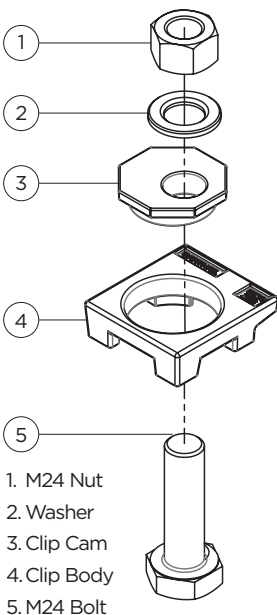

6124/20C

Gantrail Bolted Fixing

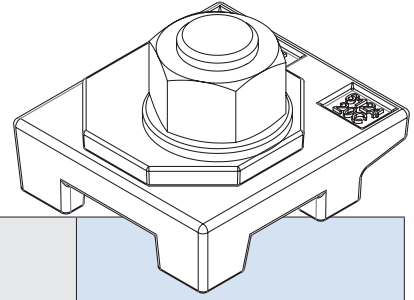

	F mm	C mm	A mm	1. CLIP REFERENCE FOR RAIL WITH PAD	2. CLIP REFERENCE FOR RAIL WITHOUT PAD*
A 75	200	75	85	N/A	6124/20C/26
A 100	200	100	95	N/A	6124/20C/26
MRS 67	131.8	79.4	146	N/A	6124/20C/26

This clip can be used for a wider selection of rails than illustrated.

Please contact GANTRAIL for the full range of possible rails. All rails can be fastened with bolted or welded base clips. GANTRAIL may change or improve their products and also alter specifications without notice.

INSTALLATION INSTRUCTIONS:

The hexagon headed fixing bolt can be inserted from above or below the supporting structure – see adjacent configurations.

If it is desired to fix the clip with a welded stud, this may be possible. Please consult GANTRAIL for guidance.

TIGHTENING TORQUE
Grade 8.8 bolt 600Nm

Please contact GANTRAIL, for full installation instructions.

BOLT CONFIGURATIONS

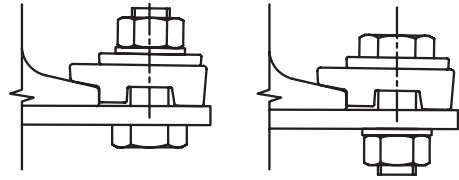

A world of crane rail expertise.

www.gantrail.com



Gantrail®
A world of crane rail expertise

Gantry Railing Ltd
Sudmeadow Road
Hempsted
Gloucester GL2 5HG
ENGLAND

Tel: +44 (0) 1452 300688
E-mail: info@gantrail.com



6124/20C/DO/04/21