

3224/20

Gantrail Bolted Fixing

www.gantrail.com



Gantrail®

A world of crane rail expertise

3224/20

The **GANTRAIL 3224/20** adjustable crane rail clip is designed to fix the largest rails in the most arduous applications. It can withstand a horizontal force from the rail of 250kN (25.5 tonnes). Its low profile allows it to be used with cranes that are fitted with guide rollers.

SPECIFICATIONS:

MAX SIDE LOAD
using Grade 8.8 bolt 250kN
20mm HORIZONTAL RAIL ADJUSTMENT

DIMENSIONS (mm):

REF No.	X	Y (FULL NUT)	Y (THIN NUT)	Z	WEIGHT kg
3224/20/42	42	50	40	26	2.10
3224/20/57	57	50	40	26	2.45

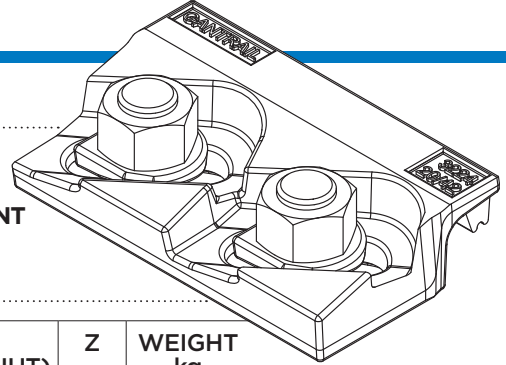

FEATURES

- The proven design has been used successfully for many years throughout the world.
- The clip is bolted to the rail support.
- The two main parts are locked together on tightening the nut.
- A special vulcanised rubber block applies a controlled force to the rail.

COMPONENTS

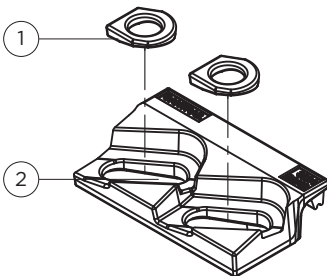

1. Special washer
2. Clip with integral rubber block

1 RAIL WITH PAD

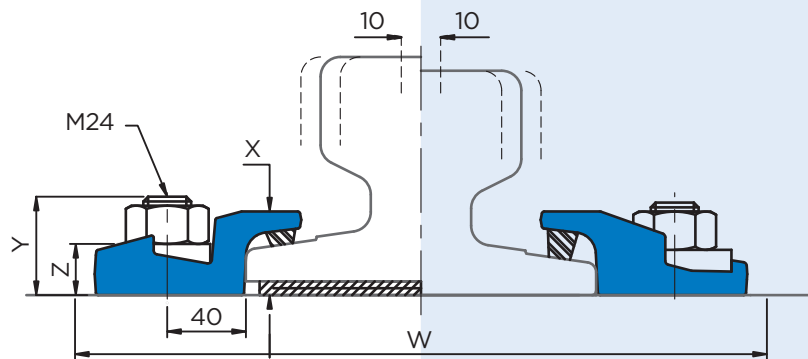

2 RAIL WITHOUT PAD

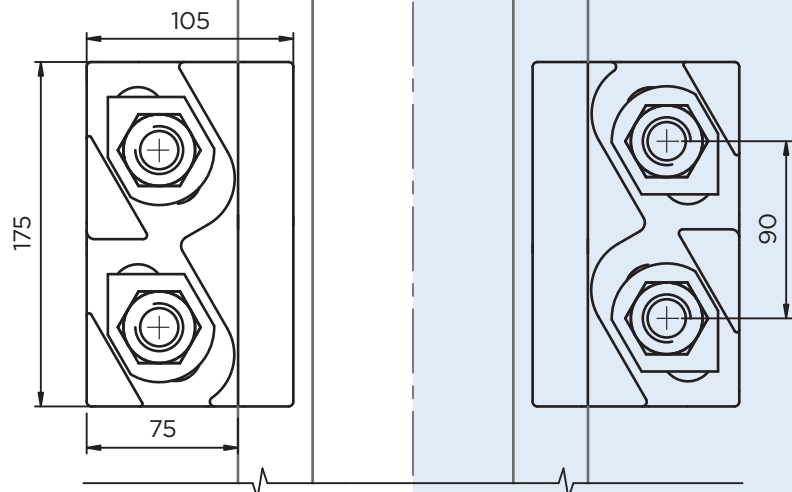

Minimum assembly width - $W = \text{Rail width (F)} + 170\text{mm}$

3224/20

Gantrail Bolted Fixing

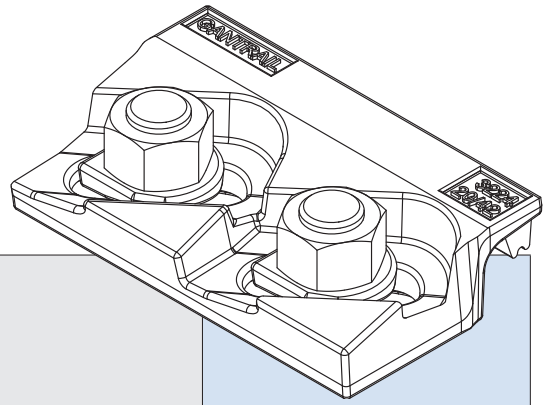

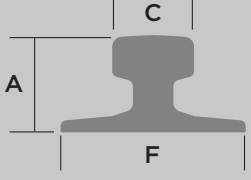
	F mm	C mm	A mm	1. CLIP REFERENCE FOR RAIL WITH PAD	2. CLIP REFERENCE FOR RAIL WITHOUT PAD
A 120	220	120	105	3224/20/42	3224/20/42
A 150	220	150	150	3224/20/42	3224/20/42
MRS 86	165	102	102	3224/20/42	3224/20/42
MRS 87 A (PRI85R)	152	102	152	3224/20/42	3224/20/42
MRS 125	180	120	180	3224/20/42	3224/20/42
ISCR 100	150	102	150	3224/20/42	3224/20/42
ISCR 120	170	120	170	3224/20/42	3224/20/42
ISCR 140	170	140	170	3224/20/42	3224/20/42
QU 100	150	100	150	3224/20/42	3224/20/42
QU 120	170	120	170	3224/20/42	3224/20/42
CR 73	140	100	135	3224/20/42	3224/20/42
86 kg AS	165	102	102	3224/20/42	3224/20/42

This clip can be used for a wider selection of rails than illustrated.

Please contact GANTRAIL for the full range of possible rails. All rails can be fastened with bolted or welded base clips. GANTRAIL may change or improve their products and also alter specifications without notice.

INSTALLATION INSTRUCTIONS:

The hexagon headed fixing bolt can be inserted from above or below the supporting structure – see adjacent configurations.

If it is desired to fix the clip with a welded stud, this may be possible. Please consult GANTRAIL for guidance.

TIGHTENING TORQUE
Grade 8.8 bolt 600Nm

Please contact GANTRAIL, for full installation instructions.

BOLT CONFIGURATIONS

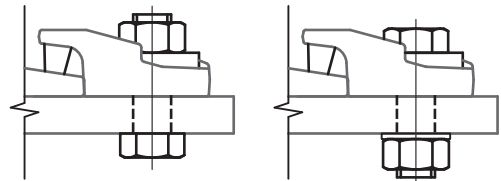

POSITIONING OF SPECIAL WASHER

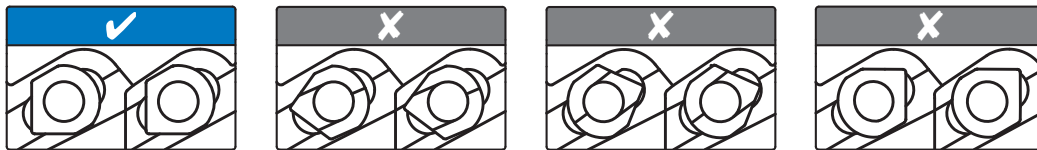

A world of crane rail expertise.

www.gantrail.com



Gantry Railing Ltd
Sudmeadow Road
Hempsted
Gloucester GL2 5HG
ENGLAND

Tel: +44 (0) 1452 300688
E-mail: info@gantrail.com



3224/20/DO/04/21