

Rails on concrete – soleplate and holding bolt sizes



www.gantrail.com

Crane rails cannot normally be directly mounted onto a concrete surface. The surface of concrete is too soft and would be worn away by the movement of the crane and rail. The upper surface of cast concrete tends to be weak as a result of the casting process. It may also not be level to the accuracy required for the crane rail. Thus it is common to bed a steel plate onto the top surface of the concrete before the rail is fixed. This then allows the Gantrail clips and pads to be accurately fixed as if the installation was on steel. Typically strong non-shrinking grout is used between the embedded sole plate and the cast concrete.

SCOPE

This note gives guidance on the choice of soleplate thickness and style. It also covers the size and length of holding down bolts. Other Gantrail sales information and technical guidance notes in this series cover the requirements for the spacing of clips on continuous soleplates and the spacing between discontinuous soleplates. The thickness of soleplates and diameter of holding down bolts is judged on the basis of experience but this needs to be backed by some calculations. A calculation is possible to confirm bolt embedment length for horizontal and vertical forces. However, Gantrail have not found any relevant rules in national or international standards. Thus the collected recommendations of grout suppliers' are used. They typically undertake many tests and develop their own design rules. Decisions are made on a basis of experience. Gantrail are always pleased to advise on the details of a particular installation.

STYLES OF SOLEPLATE FIXING

The most economical system is to fix the clip and the soleplate into position with the same holding down bolts. This is only suitable for the lightest cranes. For heavier duty cranes the holding down bolts and the clip fixing bolts are separated. Four styles of soleplate are used. The choice is dependent on the horizontal force from the crane wheels. The layout of one of these installations is shown in the drawing on page 2. This identifies all the components that are commonly used. A number of standard solutions for discontinuous soleplates are shown in a data sheet. For the heaviest installations on concrete, a continuous soleplate is used.

DISCONTINUOUS SOLEPLATE

The following decisions need to be made when designing an installation and specifying suitable products and materials:

- Are clips to be on the holding down bolts or are the holding down bolts to be separate from the clip fixing bolts?
- What number of holding down bolts will be required?
- Clip type? (Also covered in the clip selection chart)
- Pad or no pad? (Specified by the customer or covered in another note)
- Soleplate thickness?
- Soleplate width and lengths? (Also determined from Gantrail product data sheets and covered in another note)
- Holding down bolt diameter and length

For normal duty applications the arrangements in the following table are recommended. Note that if the crane duty is heavy for the size of rail; consider using the case presented on the line below in the table.

Rails on concrete – soleplate and holding bolt sizes

Vertical wheel load kN	Clips on HD bolts	Clips separate from HD bolts	Number of HD bolts	Soleplate thickness mm	HD bolt diameter mm
Up to 30	Preferred	Possible	2	10	M12
30 to 50	Possible	Preferred	2	10	M16
50 to 120	Not preferred	Preferred	2	12	M16
120 to 250	Do not use	Preferred	2 or 4	15 or more	M20
Above 250	Thickness: 20mm or more. Consider using a continuous soleplate unless the rail is very heavy and stiff or wheel load is light for the rail.				

COMPONENTS IN THE FASTENING SYSTEM

The component parts in the rail fastening system are shown in the figure. This shows only one of the examples from the table above.

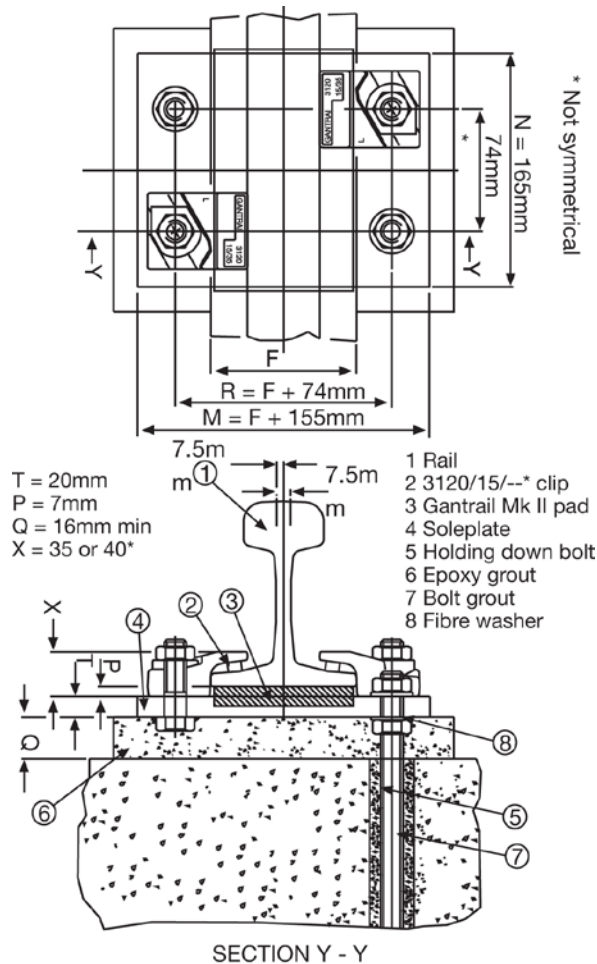

HOLDING DOWN BOLT DIAMETER

The holding down bolt diameter is typically chosen to be the same as the bolt diameter for the clip to be used. This is given by the third and fourth digit of the clip type e.g. 3116/10/32/13 has a 16 mm bolt and would normally be used with a 16 mm holding down bolt. The exception to this is when Gantrail 9220 clips are to be used it is recommended that 24 mm diameter bolts are used.

Rails on concrete – soleplate and holding bolt sizes

HOLDING DOWN BOLT LENGTH

The length of the holding down bolt needs to be determined on the basis of the horizontal and vertical wheel loads and the required bolt tension. The horizontal wheel load is also needed to determine the correct clip to use. If it is not given, it is assumed by Gantrail to be 15% of the vertical wheel load. The subject is covered in another technical note. The horizontal load is used to check that there is sufficient strength in the holding down bolts. The shear strength of the holding down bolt, when placed in high strength grout is taken as equal to:

$$V_{ult} = h_{ef} \times d_o \times f_{cm} \times 0.5 \times 1000$$

Vult = ultimate shear load capacity of holding down bolt kN

hef = effective holding down bolt length mm

do = drilled hole diameter mm

fcm = minimum concrete compressive strength (normally assumed to be 30N/mm²)

0.5 = empirically derived factor

The working load should be less than the ultimate load by a factor of safety. This is normally taken as 3. For most applications, Gantrail suggest the use of grade 4.6 holding down bolt of length to give a depth into concrete as given in the following .

Holding Down Bolt Diameter mm	Depth Of Drilled Hole In Concrete mm Grade 4.6 Bolts	Assumed Drilled Hole Diameter mm	Safe Shear Strength On Basis Of Above Calculation Method – Force kN
12	90	15	4.9
16	120	18	8.6
20	170	24	17.4
24	210	28	25.9

These are the lengths typically used in resin capsule anchoring systems. These typically give greater strength than an anchor which is fixed by mixed and poured grout but the loading on soleplates for crane rails is normally mainly in shear and not tension. Thus our application is less onerous than the normal concrete anchor. It is assumed that the total horizontal load from one wheel will be applied to one discontinuous soleplate assembly. When the holding down bolt is used to fix the clip, it is assumed that the horizontal force will all be applied to one bolt. When separate holding down bolts and clip fixing bolts are used, the force is assumed to be carried equally by the total number of holding down bolts fixing the soleplate. Continuous soleplates offer a very strong solution and it is seldom necessary to carry out detailed calculations to check their strength.

BOLT TIGHTENING

Bolt tension after tightening should not be more than 85% of bolt proof load. For simplicity Gantrail use the following approach. The design strength for embedment of a bolt is 25 mm for each tonne of load to be carried. However, the first 25 mm is ignored as it is typically weaker in tension or bearing.

The lengths in the table above should be sufficient to allow this tension. When tightening bolts, care should be exercised as the ultimate pullout load may be reached if they are over tightened. There should be a safety margin on the calculated torque to ensure the bolt or grout is not damaged. Torque wrenches are sometimes inaccurate and should not be relied upon unless correctly calibrated.

Rails on concrete – soleplate and holding bolt sizes

HIGH STRENGTH ANCHOR BOLTS

Grade 8.8 holding down bolts are approximately 2.5 times as strong in tension than grade 4.6. Thus in some applications they may be preferable. If these are to be tightened to 85% of proof load the suggested bolt depths in concrete are at least as follows. A factor of safety should be added and care should be exercised to ensure that tightening does not damage them.

Bolts Size (Grade 8.8)	Depth in Concrete mm
M12	125
M16	225
M20	325
M24	450

CONTINUOUS SOLEPLATES

Continuous soleplates of 6m long are normally used in the heavier applications. It is seldom wise to use less than 20 mm thickness for continuous soleplate as it is too flexible. If shorter soleplates of around 3m are used, then thicknesses down to 15mm are possible. The width is dictated by the rail width and the clip size.

The following table gives a guide to thickness, however, this needs to be considered in relation to the rail in use and the crane duty.

Wheel Load	Continuous Soleplate Thickness mm
Up to 30 tonnes	15 - 20 (depending on length of plate)
30 to 80 tonnes	20 - 25
Above 80 tonnes	25 or more

Holding down bolts should be fitted in pairs between the pairs of clips. They are typically specified as Grade 4.6 material. Alternatively, Grade 8.8 material may be used. However, this is seldom necessary to meet strength requirements unless there is a local uplift condition. The lengths of bolts are the same as defined for discontinuous soleplate fixing.

DESIGN RESPONSIBILITY

This technical guidance note has been prepared on the basis of many years experience at Gantry Railing Limited. However, crane rails are significant structural items in many designs and installations, and it is not possible for Gantry to fully appreciate all the local circumstances. Thus the ultimate responsibility for the design and installation must normally rest with the competent local engineer.

A world of crane rail expertise.

Gantry Railing Ltd

Sudmeadow Road, Hempsted, Gloucester GL2 5HG
www.gantrail.com

Tel: +44 (0) 1452 300688
Fax: +44 (0) 1452 300198

International: +44 (0) 1452 300688
E-mail: info@gantrail.com



Certificate No. 5180