

9112/08

Gantrail Welded Base Fixing

www.gantrail.com



The GANTRAIL 9112/08 adjustable crane rail clip is designed to fix light rails, on narrow girders, in the most arduous applications. It can withstand a horizontal force from the rail of 65kN (6.6 tonnes). Its low profile allows it to be used with cranes that are fitted with guide rollers.

SPECIFICATIONS:

MAX SIDE LOAD 65kN
8mm HORIZONTAL RAIL ADJUSTMENT

DIMENSIONS (mm):

REF No.	X	Y (FULL NUT)	Y (THIN NUT)	Z	WEIGHT kg
9112/08/23	23	35	30	17	0.26
9112/08/30	30	35	30	17	0.29

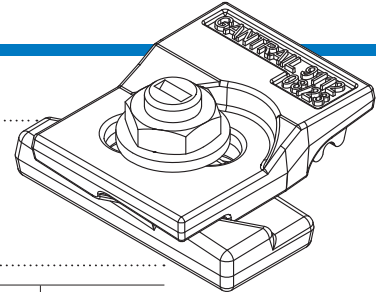

9112/08

FEATURES

- The proven design has been used successfully for many years throughout the world.
- The clip is welded to the rail support. No access is required from below.
- The two main parts are locked together on tightening the grade 8.8 bolt.
- The clip has a self-tightening mechanism.
- A special vulcanised rubber block applies a controlled force to the rail.

COMPONENTS

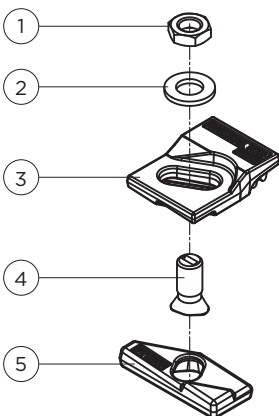

1. Nut
2. Hardened washer
3. Clip cap with integral rubber block
4. M12 Captive bolt
5. Weldable base

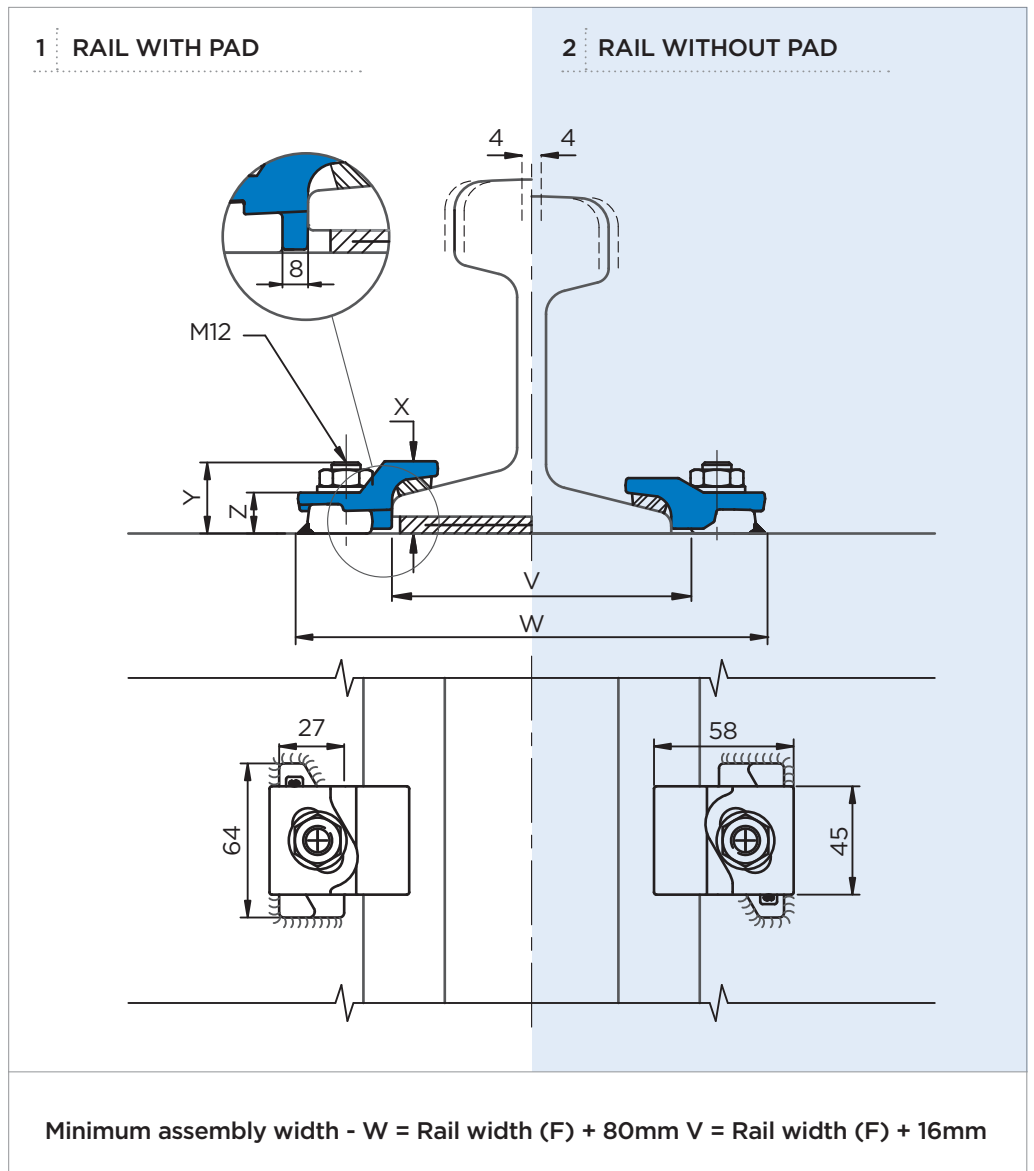

9112/08

Gantrail Welded Base Fixing

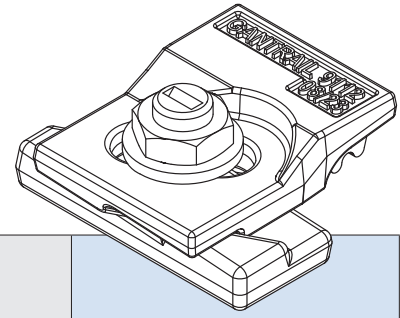

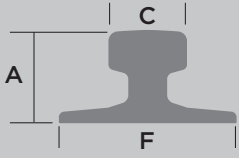
	F mm	C mm	A mm	1. CLIP REFERENCE FOR RAIL WITH PAD	2. CLIP REFERENCE FOR RAIL WITHOUT PAD
A 45	125	45	55	9112/08/30	9112/08/30
A55	150	55	65	9112/08/30	9112/08/30
S 10	58	32	70	9112/08/30	9112/08/23
S 14	70	38	80	9112/08/30	9112/08/23
S 18	82	43	92	9112/08/30	9112/08/23
S 20	82	44	100	9112/08/30	9112/08/23
S 24	90	53	115	9112/08/30	9112/08/23
S 30	180	60	108	9112/08/30	9112/08/23
ISCOR 22	95	50	95	9112/08/30	9112/08/23
ISCOR 30	110	57	110	9112/08/30	9112/08/23
JIS 12	70	38	70	9112/08/30	9112/08/23
JIS 15	79	43	79	9112/08/30	9112/08/23
JIS 22	94	51	94	9112/08/30	9112/08/23
15 kg BHP	79	43	79	9112/08/30	9112/08/23
22 kg BHP	94	51	94	9112/08/30	9112/08/23
ASCE 12	51	25	51	9112/08/30	9112/08/23
ASCE 20	67	34	67	9112/08/30	9112/08/23
ASCE 25	70	38	70	9112/08/30	9112/08/23
ASCE 30	79	43	79	9112/08/30	9112/08/23
ASCE 40	89	48	89	9112/08/30	9112/08/23
ASCE 50	98	54	98	9112/08/30	9112/08/23
ASCE 60	98	54	98	9112/08/30	9112/08/23

This clip can be used for a wider selection of rails than illustrated.

Please contact GANTRAIL for the full range of possible rails. All rails can be fastened with bolted or welded base clips. GANTRAIL may change or improve their products and also alter specifications without notice.

INSTALLATION INSTRUCTIONS:

Weld all round the clip base, except the side closest and parallel to the rail, with a 3mm throat thickness fillet weld, using low hydrogen electrodes. Recommended electrodes AWS E7018 or E7028. Clip base is made from weldable grade steel.

If a continuous weld around the base is required, this is possible. Please consult GANTRAIL for guidance.

TIGHTENING TORQUE 60Nm

Please contact GANTRAIL, for full installation instructions.

WELD DETAIL

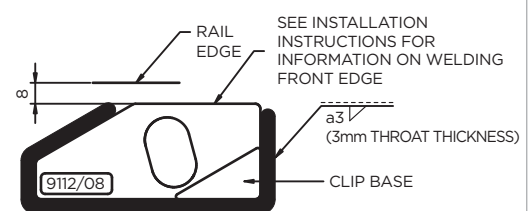

A world of crane rail expertise.

www.gantrail.com



Gantry Railing Ltd
Sudmeadow Road
Hempsted
Gloucester GL2 5HG
ENGLAND

Tel: +44 (0) 1452 300688
E-mail: info@gantrail.com



9112/08/DO/08/24