

9220/30

Gantrail Welded Base Fixing

www.gantrail.com



Gantrail[®]

A world of crane rail expertise

The **GANTRAIL 9220/30** adjustable crane rail clip is designed to fix the largest rails in the most arduous applications. It can withstand a horizontal force from the rail of 300kN (30.6 tonnes). Its low profile allows it to be used with cranes that are fitted with guide rollers.

SPECIFICATIONS:

MAX SIDE LOAD 300kN
30mm HORIZONTAL RAIL ADJUSTMENT

DIMENSIONS (mm):

REF No.	X	Y	Z	WEIGHT kg
9220/30/44	44	49	33	3.98

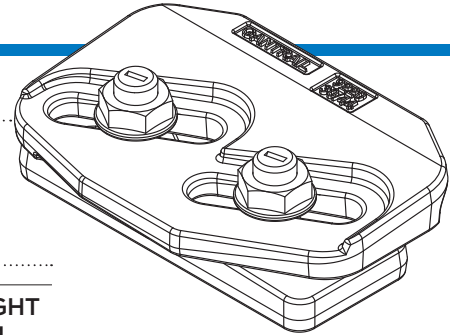

9220/30

FEATURES

- The proven design has been used successfully for many years throughout the world.
- The clip is welded to the rail support. No access is required from below.
- The two main parts are locked together on tightening the grade 8.8 bolts.
- The clip has a self-tightening mechanism.
- A special vulcanised rubber block applies a controlled force to the rail.

COMPONENTS

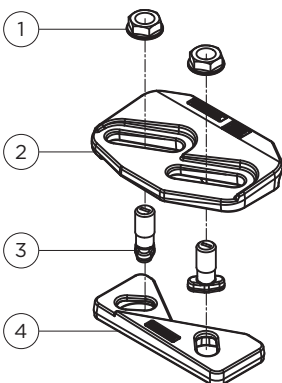

1. Flange nuts
2. Clip cap with integral rubber block
3. M20 Captive bolts
4. Weldable base

1 RAIL WITH PAD

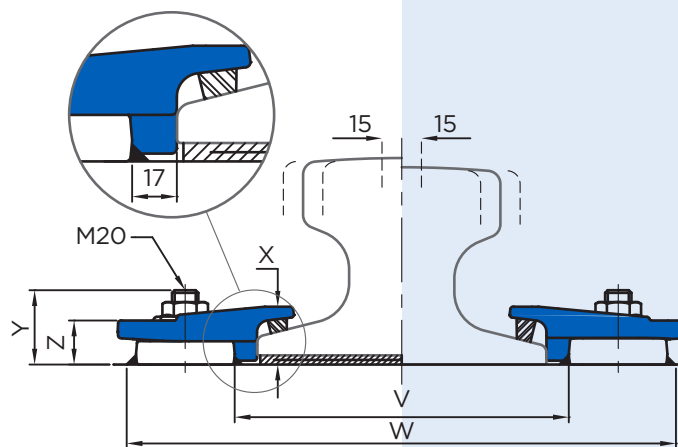

2 RAIL WITHOUT PAD

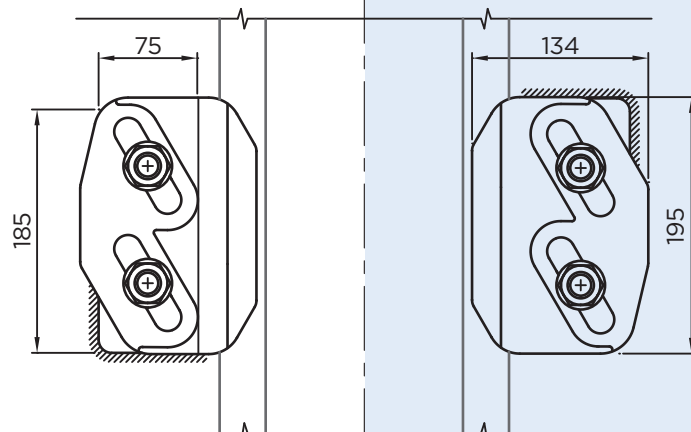

Minimum assembly width - $W = \text{Rail width (F)} + 200\text{mm}$ $V = \text{Rail width (F)} + 34\text{mm}$

9220/30

Gantrail Welded Base Fixing

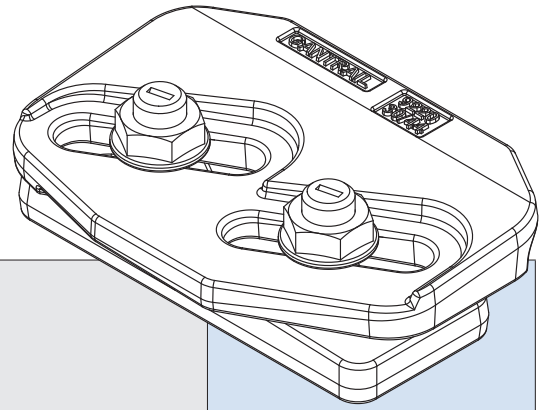

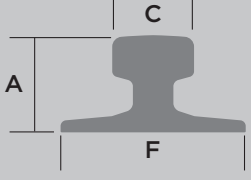
	F mm	C mm	A mm	1. CLIP REFERENCE FOR RAIL WITH PAD	2. CLIP REFERENCE FOR RAIL WITHOUT PAD*
A 120	220	120	105	9220/30/44	-
A 150	220	150	150	9220/30/44	9220/30/44
89 kg CR	178	102	114	9220/30/44	9220/30/44
MRS 86	165	102	102	9220/30/44	-
MRS 125	180	120	180	-	9220/30/44
MRS 221	220	220	160	9220/30/44	9220/30/44
ISCR 120	170	120	170	9220/30/44	9220/30/44
KP 140	170	140	170	9220/30/44	9220/30/44
QU 120	170	120	170	9220/30/44	9220/30/44
CR 100	155	120	150	9220/30/44	9220/30/44

This clip can be used for a wider selection of rails than illustrated.

Please contact GANTRAIL for the full range of possible rails. All rails can be fastened with bolted or welded base clips. GANTRAIL may change or improve their products and also alter specifications without notice.

INSTALLATION INSTRUCTIONS:

Weld all round the clip base with a 5mm throat thickness fillet weld, using low hydrogen electrodes. Recommended electrodes AWS E7018 or E7028. Clip base is made from weldable grade steel.

* For rail without pad, weld closest to and parallel with the rail must be omitted. Please consult GANTRAIL for guidance.

TIGHTENING TORQUE 350Nm

Please contact GANTRAIL, for full installation instructions.

WELD DETAIL

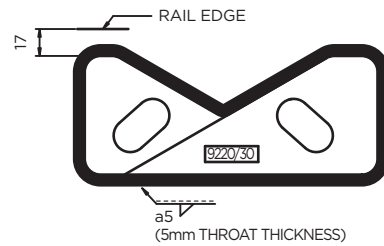

A world of crane rail expertise.

www.gantrail.com



Gantrail®
A world of crane rail expertise

Gantry Railing Ltd
Sudmeadow Road
Hempsted
Gloucester GL2 5HG
ENGLAND

Tel: +44 (0) 1452 300688
E-mail: info@gantrail.com



9220/30/DO/04/21